



POWERLOGIC® Energy Meter

INTRODUCTION

Applications

- Tenant submetering
- Performance contracting
- Cost allocation
- Real time power monitoring via local display or POWERLOGIC or control/data acquisition system

Fast Trouble-free Installation

- Split-core CTs eliminate the need to remove electrical conductors
- Meter automatically detects phase reversal and eliminates concerns about CT orientation
- CTs and voltage terminals are color coded, making it easy to determine matching
- Low-output voltage CTs eliminate the need for shorting bars

Exceptional Systems Accuracy

- $\pm 1\%$ system accuracy meets ANSI C12.16 metering accuracy standards

FCC PART 15 INFORMATION

NOTE: This equipment has been tested by the manufacturer and found to comply with the limits for a class A digital device, pursuant to part 15 of the FCC Rules. These limits are designed to provide reasonable protection against harmful interference when the equipment is operated in a commercial environment. This equipment generates, uses, and can radiate radio frequency energy and, if not installed and used in accordance with the instruction manual, may cause harmful interference to radio communications. Operation of this equipment in a residential area is likely to cause harmful interference, in which case the user will be required to correct the interference at his own expense. Modifications to this product without the express authorization of Square D nullify this statement.

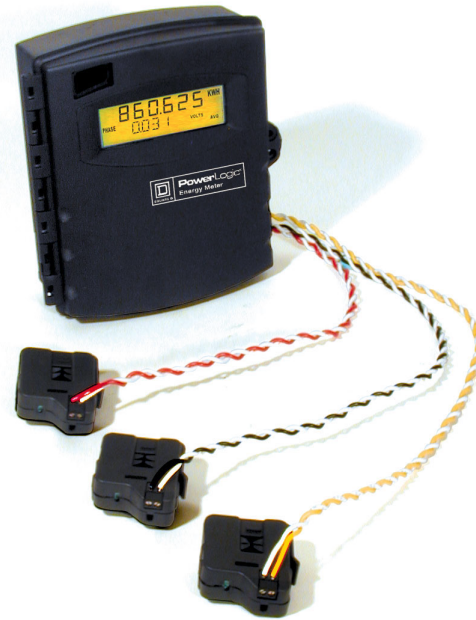

Figure 1: Energy Meter and CTs

The POWERLOGIC Energy Meter combines highly accurate industrial grade split-core CTs and precision microprocessor based metering electronics to provide exceptional metering accuracy and greatly reduce the total metering system installed cost. The accuracy of the Energy Meter is plus or minus one percent of reading from two percent (2 A with a 100 A CT) to one hundred percent of the current rating of the CT.

The meter display provides valuable installation diagnostics. If the meter is installed and the CTs and voltage leads are not properly matched, the display gives the installer feedback as to what is wrong. The POWERLOGIC Energy Meter comes in two different models: Basic and Extended Range.

The **Basic** model is a display meter designed for direct monitoring of 240/120 V and 208Y/120 V services and is ideal for stand-alone metering applications. The standard IR communications port and Palm OS® organizer compatibility provide a simple way to accurately acquire and report energy information. Information stored in the organizer can be synched to a PC in text format, which can easily be imported into applications such as Microsoft Excel.

The **Extended Range** model provides an extended input voltage range (120–480 Vac, auto-ranging), a pulse output for easy integration with control systems, and a phase loss output to help protect equipment.

If equipped with a communications board and connected to a POWERLOGIC or MODBUS control/data acquisition system, the Energy Meter reports energy and power diagnostics variables such as kWh, kW, PF, kVAR, Volts, and amperes.

DESCRIPTION

- A** IR Communications Port for easy download to Palm OS Organizer
 - B** Large Digit Backlit Meter and diagnostics display
 - C** Security Hasp
 - D** CT Input Terminals. Ensure that voltage lead and CT are properly matched (e.g. red on red, page 5).
 - E** Voltage Input Terminals: Ensure that voltage lead and CT are properly matched (for example: red on red, see page 5).
 - F** *Pulse Rate Terminal: Provides easy integration to existing control/data acquisition systems (see page 6).
 - G** *Phase Loss Output Alarm: Trips if phase voltage drops 25% (see page 8).
 - H** *Pulse Output Selection Switch: Set the pulse output at 0.1, 0.25, 0.50, or 1 pulse/kWh to match resolution requirements (see page 6).
 - I** Reset: To reset the kW max reading, press and hold both buttons at the same time for 5 seconds. To reset the kWh counter and the kW max, press and hold both buttons at the same time for 10 seconds (see page 8).
 - J** Backlight Enable Jumper: Remove this jumper to disable lighting (see page 6).
 - K** Plain/Full Display Data Jumper (see page 7).
- *Features available on Extended Range model.

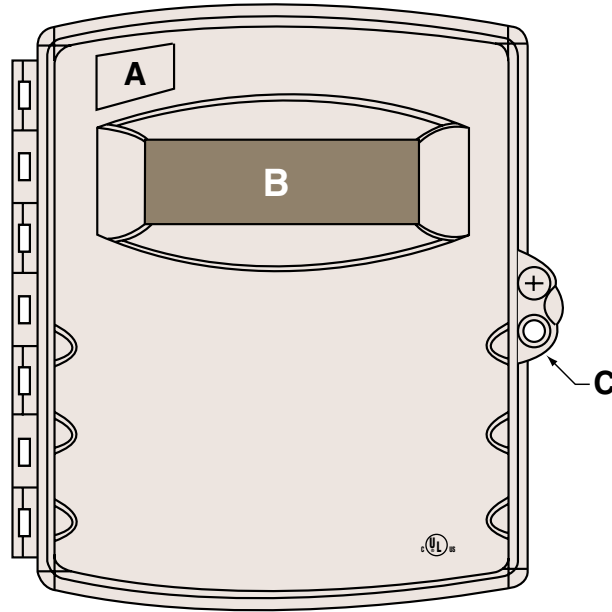

Figure 2: Energy Meter display

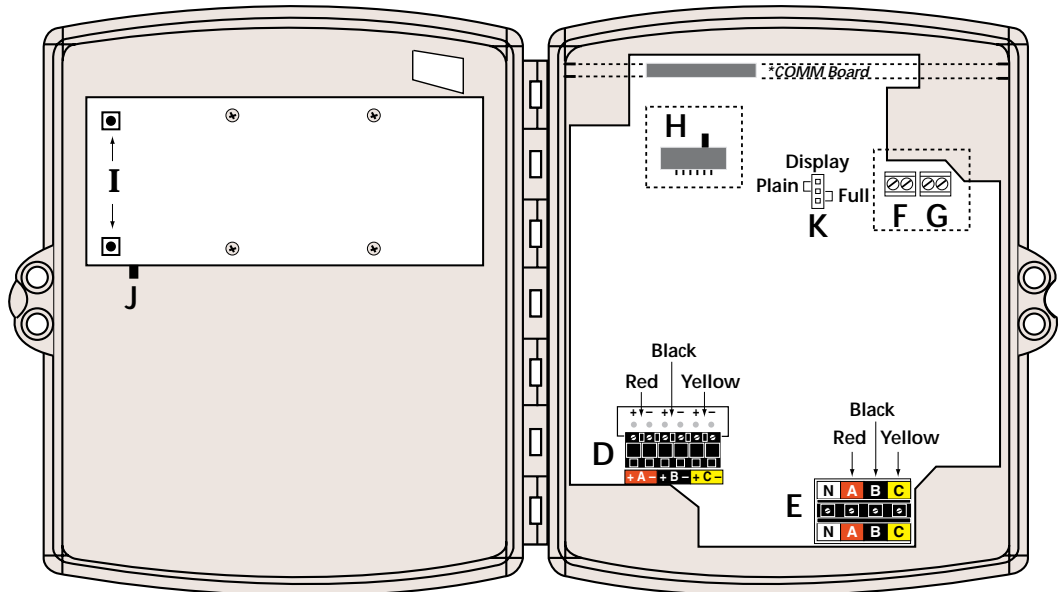

Figure 3: Color match CTs and voltage leads

INSTALLATION

Installation should be performed by qualified personnel familiar with applicable codes and regulations. The meter enclosure is designed for indoor use only.

Install the Energy Meter within 20 feet (5m) of the desired CT location. CT wiring should be 18 AWG twisted leads with 600V insulation (UL 1015 or equivalent). To prevent tampering, secure the meter with a padlock or a similar device.

To install the Energy Meter, follow these steps:

1. Disconnect power and lock out all power sources during installation and configuration. **DO NOT CONNECT VOLTAGE INPUTS LIVE!**

⚠ DANGER

HAZARD OF ELECTRIC SHOCK, BURN, OR EXPLOSION

- Turn off and lock out all power supplying the energy meter and the equipment to which it is installed before working on it.
- Always use a properly rated voltage sensing device to confirm that power is off.
- If the connections to the meter will be made through more than one metallic conduit, the conduits will require bonding to prevent the hazard of electric shock. A bonding plate is available (P/N: EMBOND), or an equivalent means may be used.

Failure to observe this instruction will result in death, serious injury, or equipment damage.

2. If the connections to the meter will be made through more than one metallic conduit, bond the conduits (see Figure 4) with a bonding plate (P/N: EMBOND) to prevent the hazard of electric shock.

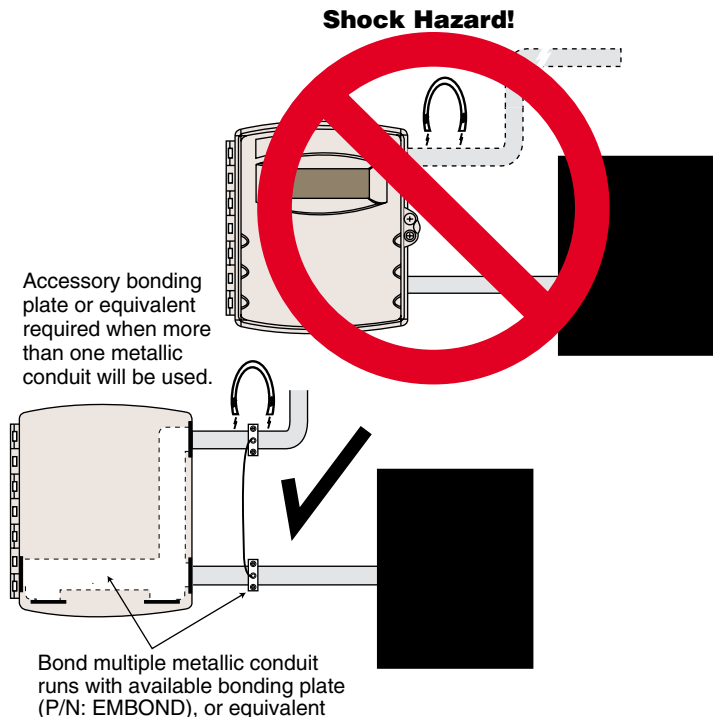

Figure 4: Bonding conduit with bonding plate

3. If using a hub on rigid conduit, assemble the hub to the conduit before attaching to the meter.
4. Mount the meter box at an appropriate height, allowing for use with an organizer, or direct vision as illustrated below.

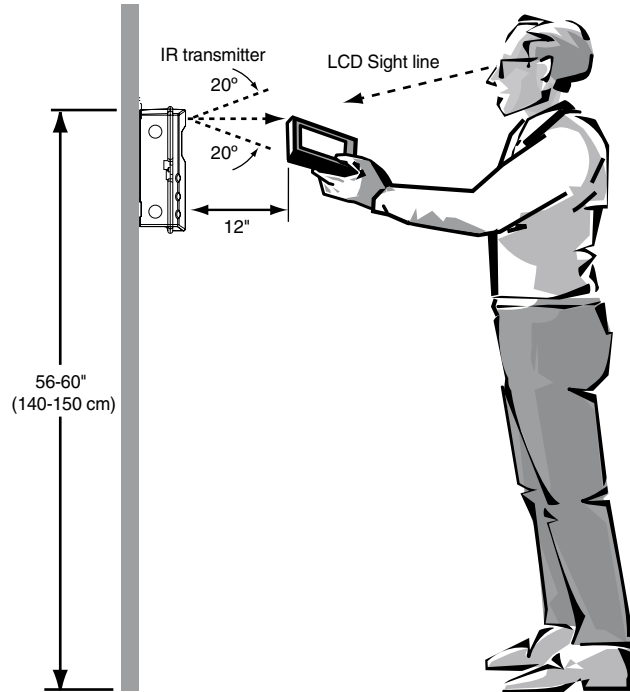

Figure 5: Setting mounting height for Energy Meter

5. Mount fuse block and fuses (Figure 6).

NOTE: External fusing must be provided by installer, or purchased as an accessory (P/N: EMFP1, EMFP2, or EMFP3), to comply with local and national codes. Fuse rating must be adequate to the applied voltage, with a current rating of 1/2 A (T) SLO-BLO. To comply with the requirements of the IEC, and others, the fuse installation must be visible from the meter, or be provided with a lockout/tagout disconnect.

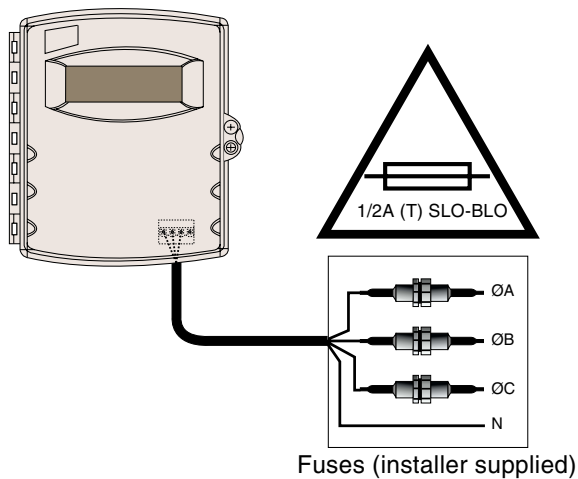

Figure 6: Fuse installation

- Attach CTs to conductors. The meter automatically detects phase reversal, so it is not necessary to orientate a particular side of the CTs toward the load. A mounting bracket may be desirable to meet local inspection requirements, and/or to maximize accuracy. Specified accuracy is achieved by passing the conductor through the geometric center of the CT window.

NOTE: For service across the full ambient temperature/load range, 1600A CTs in contact with the conductor must be used with 90° C wire insulation, or be derated appropriately.

- Attach CT leads to appropriately colored CT input terminals (e.g., red lead to red terminal) as shown (see Figure 7 through Figure 9). Polarity is indicated, with the minus (-) terminals connected to neutral within the meter, but polarity is insignificant to the operation of the meter.
- Connect voltage leads to phase conductors as shown (see Figure 7 through Figure 9). Connect leads from the colored voltage terminals to the power conductor with the matching CT (e.g., red CT lead to red terminal). Since the meter is powered from the monitored source (red and neutral terminals), it is important to connect the voltage leads to a circuit that is not normally switched off.

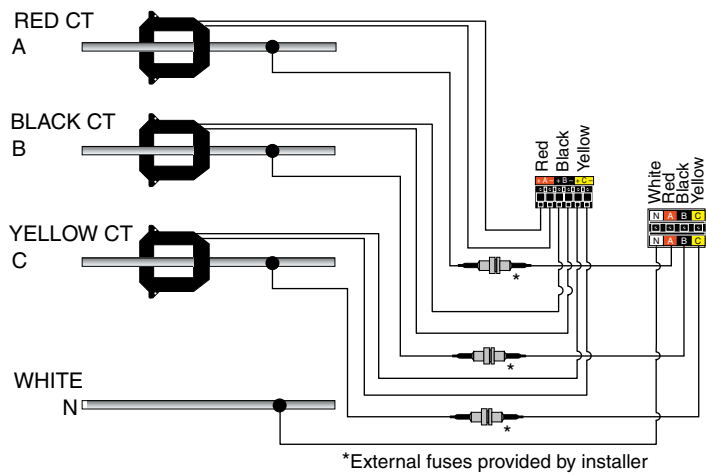

Figure 7: 3-phase, 4-wire installation

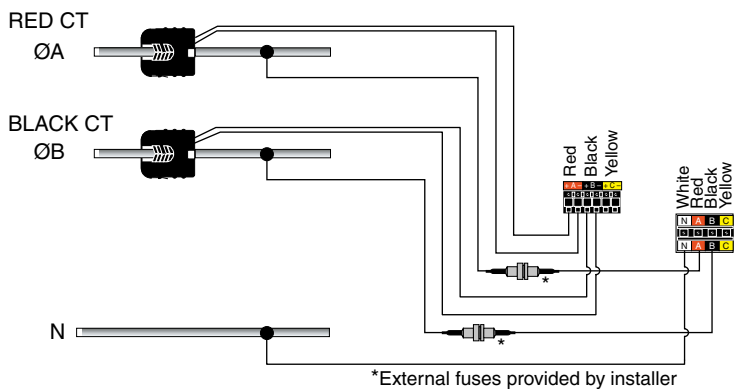

Figure 8: 1-phase, 3-wire installation

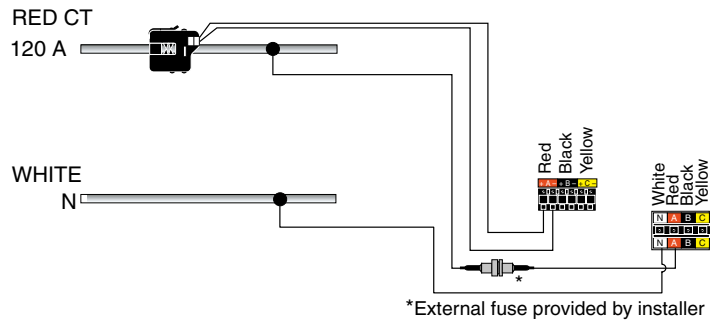

Figure 9: 1-phase, 2-wire installation

9. For the Extended Range model: To connect the energy consumption pulse output to a control/data acquisition system (DAQ), wire the pulse output (shown in Figure 3) to the controller. Output is an electronic N.O. “contact closure” rated for 24V AC/DC @ 100mA maximum. Ensure that the installation method and insulation ratings comply with local and National Electrical Codes.
Set pulse rate slide switch: Set to desired output rate. Note that 0.1 is not valid for 1600A systems, and 0.1 and 0.25 are not available for 5000A systems. (Availability of 5000A Energy Meter is scheduled for 2001.)
10. For the Extended Range model: To connect the phase loss output to control/data acquisition system, wire the phase loss output (shown in Figure 3) to the controller/DAQ system. Output is an electronic N.C. “contact closure” rated for 24V ac/dc @ 100mA. maximum. Ensure that installation method and insulation ratings comply with local and National Electrical Codes.
11. Set the Backlight Enable Jumper to the desired operating condition (refer to Figure 10). The unit is shipped with the jumper in the enable mode. Remove the jumper to disable the LCD backlight.

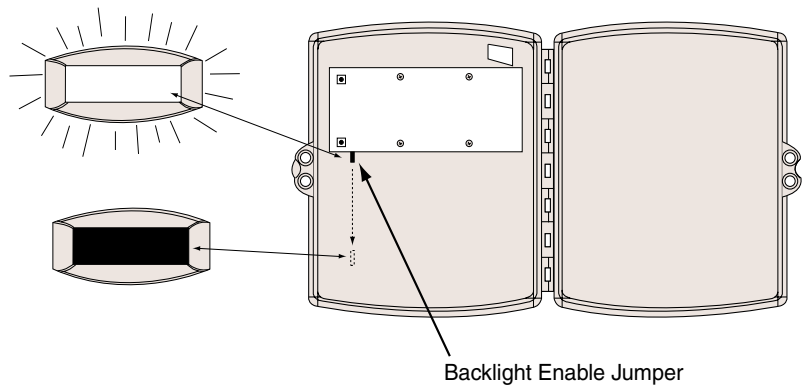

Figure 10: Enabling and disabling the LCD backlight

12. Set the display data jumper to select between the “Plain” and “Full” settings. The “Plain” mode displays WHRS and cycles through five data elements (kW, kW Max, average power factor, line-to-line voltage, and amps) for four seconds each. The “Full” mode displays WHRS and cycles through all of the data available from the meter (all the above, plus kVAR, and data on individual phases), as shown in Figure 11. When the COMMS board is installed, kW Demand is also displayed.

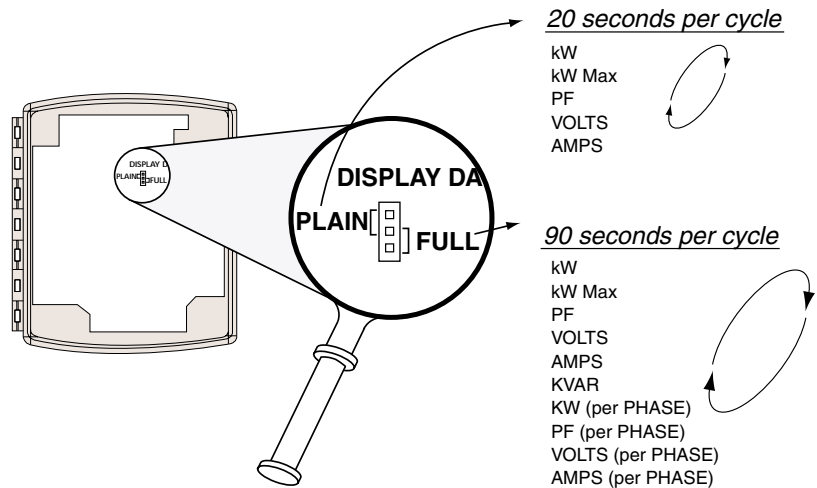

Figure 11: Setting the display data jumper

OPERATION and INFORMATION REPORTING

Power-Up

On power-up, the meter displays the firmware revision and checks each connection to ensure that the CT and voltage leads have been properly matched. A warning message will indicate each phase that is found to be mismatched. (Note: the meter uses low Power Factor to determine improper phase matching.)

1. Apply power to the meter.
2. Check the meter display. The meter checks each phase to ensure that the phasing is correct. If the phasing is correct, the meter responds with OKAY. If the phasing of the CT and voltage leads are incorrect, the meter displays "ERROR CHECK WIRES RED* CT RED* VOLT LEAD SAME PHASE." *appropriate color
3. Approximate check of power reading:
Check actual current with amp clamp. Expected power is:
kW = Volts x Amps x 1.732 x PF x 1000 (for three phase)
kW = Volts x Amps x PF x 1000 (for single phase)

Information Displayed When Meter is Running

The energy meter continually reports kilowatt hours (kWH) or megawatt hours (MWH), depending on the the total energy accumulated.

A secondary display cycles through other parameters. There are two modes of operation, depending on the setting of the DISPLAY DATA jumper (J8) on the main circuit board:

PLAIN: kW, kW Max, PF, VOLTS, AMPS

FULL: kW, PF, VOLTS, AMPS, KVAR, kW-A**, kW-B**, kW-C***,
PF-A**, PF-B**, PF-C***, VOLTS A-B***, VOLTS B-C***,
VOLTS A-C***, VOLTS A-N**, VOLTS B-N**, VOLTS C-N***,
AMPS-A**, AMPS-B**, AMPS-C***, kWD*

Every 10th rotation of parameters, the following parameters are also displayed: "PULSE-RATE****, ADDRESS*, BAUD-RATE*, PARITY*, and 2/4WIRE**"

- *Only if Comms board installed
- **2 and 3-CT meters only
- ***3-CT meters only
- **** Extended Range model only

Alarms

The following alarm messages remain on the lower display as long as the alarm condition persists:

Phase Loss

If the voltage of any phase is measured as less than 75% of the voltage on any other phase, the display will show PHASE LOSS and indicate the specific phase(s).

Over Current

If the measured current is greater than 110% of the rated CT range, the display will show AMPS OVER and indicate the specific phase(s).

Over Voltage

The error thresholds differ between the Basic and Extended Range meters:

Basic: Volts A-N, B-N or C-N greater than 132 Vac.

Extended Range: Volts A-C, B-C or A-C is greater than 528 Vac.

If an error is detected, the display will show VOLTS OVER and indicate the specific phase(s).

Meter/Display Configuration

⚠ WARNING

HAZARD OF ELECTRIC SHOCK

Only qualified personnel should open the unit. Avoid contact with components inside the right compartment while power is on.

Failure to observe this instruction can result in death or serious injury.

kW Max Reset: Press and hold the two pushbuttons on the back of the LCD display board at the same time for 5 seconds. Confirmation of kW max reset is indicated on the display by showing "kW Max," "Status," and "Reset." If the optional COMMS board is present, the kW max reset is disabled. The kW demand, which is available with the optional COMMS board, is programmed and reset via network communications commands.

kWh and kW Max Reset: To reset both readings, press and hold the two push-buttons on the back of the LCD display board at the same time for 10 seconds. Confirmation of reset is indicated by showing "0 kWh." If the optional COMMS board is present, the kW max reset is disabled. The kW demand, which is available with the optional COMMS board, is programmed and reset via communications.

Palm OS® Configuration

See CD-Rom (P/N: EMCD) included with the unit.

TROUBLESHOOTING

Problem	Check	Solution
No display readout	Voltage at voltage terminals	Check external fuses
	Is the input power to the meter switched?	We recommend that the voltage connections be made to a point ahead of commonly operated switches, motor controllers, etc., but not ahead of service disconnect device.
	Display cable	Assure that the ribbon cable from the main circuit board to the display has not been disconnected during installation.
	Wiring to product	Is A–N voltage other than 120 Vac on Basic model? Correct voltage input: Basic model must have 120 Vac applied between “N” and “A” voltage terminals. Extended Range model also requires a neutral connection.
	CT power terminals (holes on PC board)	Don't allow conductive materials (wire clippings, etc.) to short between the holes in the main board near the CT terminals, as these connect to the main power supply.
Too much (or too little) display data	Display data jumper	Set jumper to correct position (see Figure 11).
No IR communication	Angle and distance of Palm OS organizer from IR window	Hold the Palm OS organizer 12 inches away from, and within a 20° cone from, the lower left corner of the IR window (dark area at the upper left corner of the meter).
	Energy Meter software installed?	Install Energy Meter software from CD.
No pulse output (Extended Range model)	Supply voltage	The pulse output is a contact closure only — power must be supplied externally in the range of 5–24 V ac/dc, with a maximum load of 100mA.
	Signal timing	The pulse output provides a contact closure for 200ms at each pulse time. Be sure the controller will accept this signal as an input.
Pulse output wrong; display okay	Pulse rate switch	Set the pulse rate switch and controller to match. Pulse rate switch selects 0.1, 0.25, 0.5, or 1.0 kWh/pulse (see page 6).
Phase loss output (extended range model)	State of output	This output is normally closed (N.C.). Therefore, it is closed at all times when the meter is correctly powered.
	No output	This output is a contact closure only and requires an external power supply in the range of 5–24 V ac/dc, with a maximum load of 100mA.
Reported power too low	CT match to voltage terminals	The CTs must be mounted around the corresponding voltage terminal's power conductor (e.g., the red CT must be mounted to the power conductor connected to the red voltage terminal). The same is true for any other CT/voltage terminal pairs.
		Check for phase loss.
		Check fuses in voltage leads (field installed).
Reported power inaccurate	CT serial numbers	The CTs are calibrated to individual meters and must be connected to the meter with which they were calibrated to assure optimum accuracy.

SPECIFICATIONS

General

LCD display	Physical 1.2 in. by 3.8 in., back lit with green LEDs
CT case isolation	600 Vac, IEC 1010 Cat. III/2
Sample rate	1280 Hz.
Internal isolation	2500 Vac Basic, 320 Vac Extended Range
Operating temperature range	0 to 50°C (<95% RH, non-condensing)
Storage temperature range	-40°C to 70°C
Systems accuracy	±1% of reading from 2% to 100% of the CT current rating...accomplished by matching the CTs with a meter and calibrating them as a system
Power source.....	Basic model: Line powered 120 Vac (line to neutral) Extended Range model: Line powered 120 Vac through 277 Vac (line to neutral)
Voltage tolerance	75–110% of nominal voltage (line-to-neutral)
Services	Basic model: 240/120 Vac, 208Y/120 Vac Extended Range model: 1Ø2W, 1Ø3W, 3Ø4W 120–480 Vac
Frequency.....	50/60 Hz.

COMMS Board Option

MODBUS Communications

Output type.....	MODBUS RTU
Connection	2-wire or 4-wire
Baud rate	2400, 4800, 9600, or 19200 baud
Parity	None, Odd, or Even
Address	1–63
Data Output.....	Refer to Energy Meter COMMS Board Instruction Bulletin

DIMENSIONS

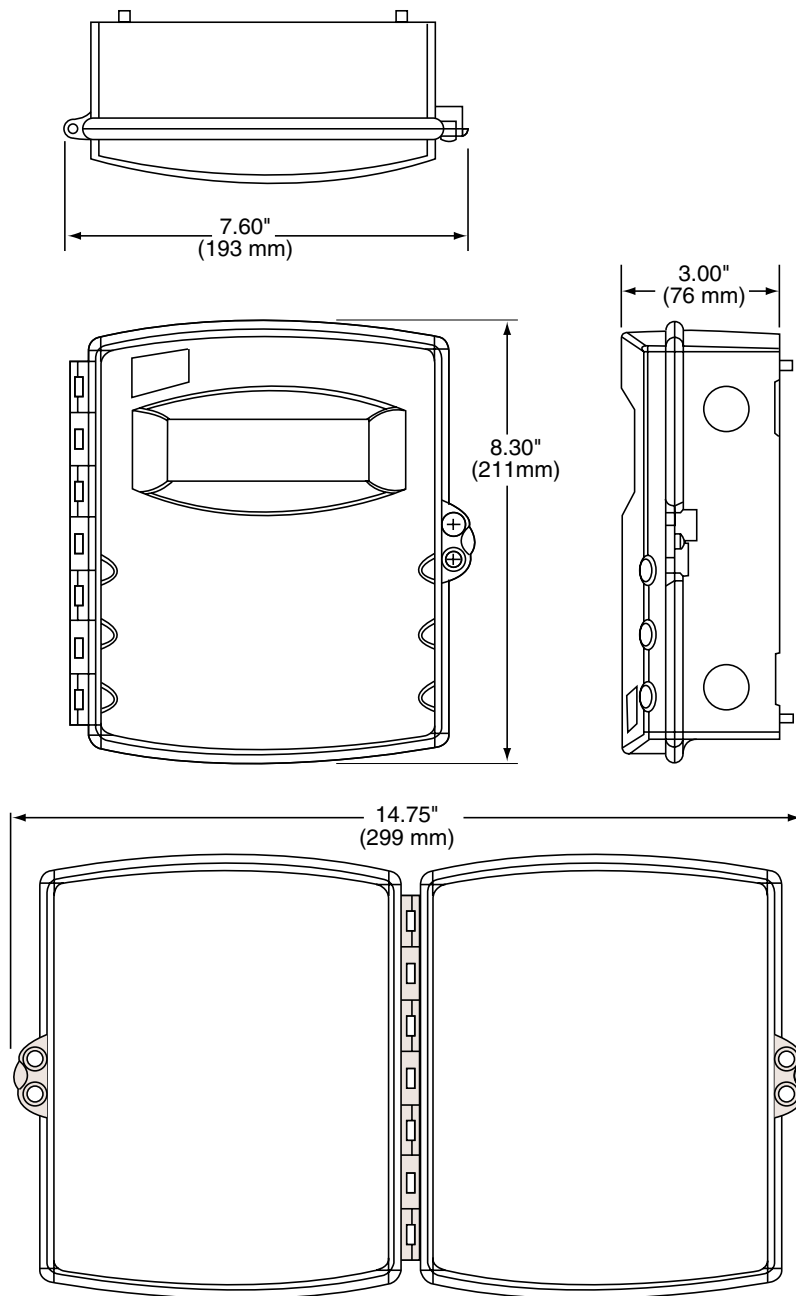
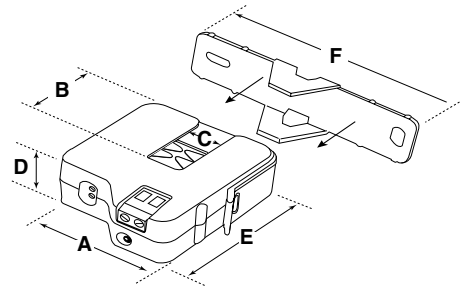
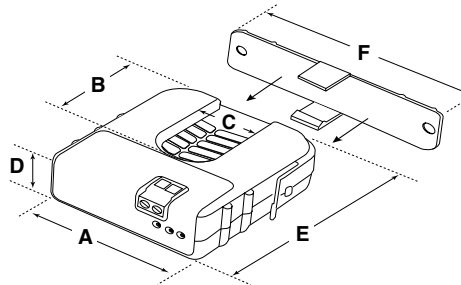

Figure 12: Energy Meter Dimensions



Size 0

A =	2.0"	(55 mm)
B =	1.28"	(33 mm)
C =	.518"	(13 mm)
D =	.915"	(23 mm)
E =	2.34"	(60 mm)
F =	3.52"	(90 mm)



Size 1

A =	2.58"	(81 mm)
B =	1.90"	(48 mm)
C =	.90"	(23 mm)
D =	1.04"	(26 mm)
E =	2.90"	(74 mm)
F =	3.52"	(90 mm)

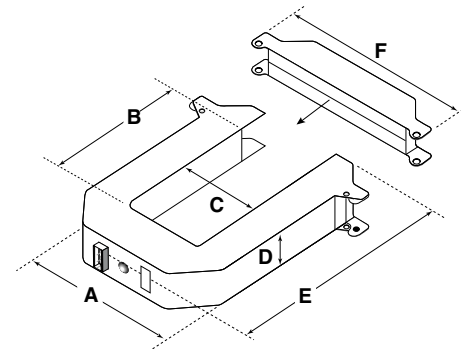

Size 3

A =	4.90"	(124 mm)
B =	2.89"	(73 mm)
C =	2.45"	(62 mm)
D =	1.13"	(29 mm)
E =	5.57"	(141 mm)
F =	5.91"	(150 mm)

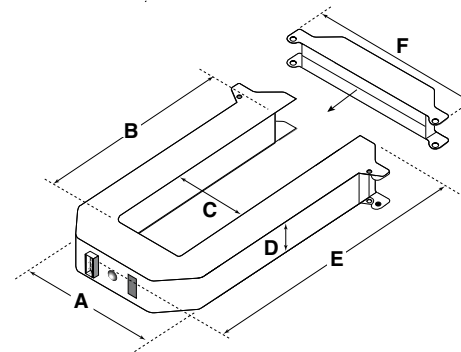

Size 4

A =	4.90"	(124 mm)
B =	5.50"	(140 mm)
C =	2.45"	(62 mm)
D =	1.13"	(29 mm)
E =	8.13"	(207 mm)
F =	5.92"	(150 mm)

Figure 13: CT Dimensions

Electrical equipment should be serviced only by qualified maintenance personnel. No responsibility is assumed by Square D for any consequences arising out of the use of this material.