

170AMM11030 Analog/Digital Momentum I/O Base User Guide

Version 1.0

31005009 01



Telemecanique

Safety Information

NOTICE

Read these instructions carefully, and look at the equipment to become familiar with the device before trying to install, operate, or maintain it. The following special messages may appear throughout this documentation or on the equipment to warn of potential hazards or to call attention to information that clarifies or simplifies a procedure.



The addition of this symbol to a Danger or Warning safety label indicates that an electrical hazard exists, which will result in personal injury if the instructions are not followed.



This is the safety alert symbol. It is used to alert you to potential personal injury hazards. Obey all safety messages that follow this symbol to avoid possible injury or death.



DANGER

DANGER indicates an imminently hazardous situation, which, if not avoided, **will result** in death, serious injury, or equipment damage.



WARNING

WARNING indicates a potentially hazardous situation, which, if not avoided, **can result** in death, serious injury, or equipment damage.



CAUTION

CAUTION indicates a potentially hazardous situation, which, if not avoided, **can result** in injury or equipment damage.

PLEASE NOTE

Electrical equipment should be serviced only by qualified personnel. No responsibility is assumed by Schneider Electric for any consequences arising out of the use of this material. This document is not intended as an instruction manual for untrained persons.

© 2003 Schneider Electric

All Rights Reserved.

170AMM11030 Analog/Digital Momentum I/O Base

Overview

This document contains the following topics:

Topic	Page
Front Panel Components	3
Specifications	5
Internal Pin Connections	9
Field Wiring Guidelines	10
Wiring Diagrams	11
I/O Map	12
Register for Outputs	13
4x Registers	15
Register for Inputs	16
Analog Map	19
Discrete I/O Points and IEC Compliant Data Mapping	20
Input and Output Ranges	21

Front Panel Components

Overview

This section contains an illustration of the front panel of the 170AMM11030 I/O base and a description of the LEDs.

Front Panel Illustration

The illustration below shows the front panel of the I/O base.

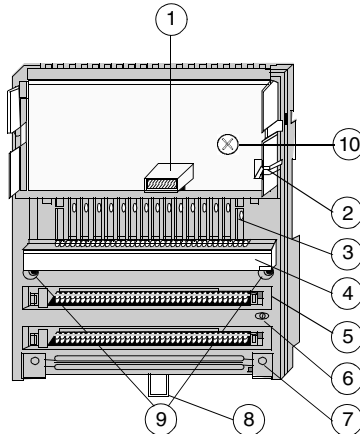

Components of the I/O Module:

Label	Description
1	Internal interface (ATI) connector
2	Locking and ground contact for the adapter
3	LED status display
4	Protective cover
5	Sockets for the terminal connectors
6	Grounding screw
7	Busbar mounting slot
8	Locking tab for DIN rail mount
9	Mounting holes for panel mount
10	Standoff -- ground nut

LED Illustration

The illustration below shows the LEDs.

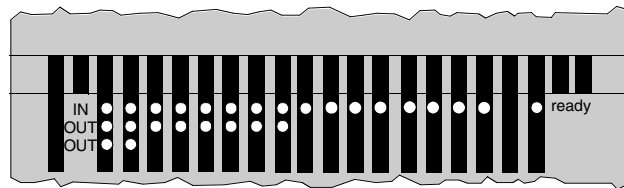

LED Descriptions

The following table describes the LEDs.

LED	Color	Status	Meaning
Ready	Green	ON	I/O base is communicating with the comm adapter/CPU top hat. CPU must be in RUN state.
I1, I2, I3, I4, I5, I6, I7, I8, I9, I10, I11, I12, I13, I14, I15, I16	Green	ON	Indicates the corresponding input point is ON.
O1, O2, O3, O4, O5, O6, O7, O8	Green	ON	Indicates the corresponding discrete output point is ON.
AO1, AO2	Green	ON	Indicates the corresponding analog output channel is active.

Specifications

Overview

This section contains specifications for the 170AMM1 1030 Momentum I/O base.

General Specifications

The following table contains general specifications for the I/O base. Each discrete output is protected against short-circuiting and overload.

External Power Requirement	
Normal Operating Voltage Range	16 to 42 VDC
Absolute Minimum Voltage	12 VDC
Absolute Maximum Voltage	45 VDC
Electrical	
Module Current	400 mA at 24 VDC
EMC for Industrial Environment	
Immunity	IEC 1131-2 Surge on auxiliary power supply 500 V
Emissions	EN 50081-2
ENV 50140	10 V/M
Agency Approvals	UL, CSA, CE, FM Class 1, Div. 2 (pending)
Isolation	
Discrete I/O point to discrete I/O point	None
Field to ground	500 VAC
Field to communication adapter	500 VAC
Analog output channel to channel	700 VDC
Environmental	
Storage Temperature	-40 to 85° C
Operating Temperature	0 to 60° C
Humidity Operating	95% RH @ 60° C
Humidity Non-Operating	95% RH @ 60° C
Vibration Operating	10 - 57 HZ 0.075 MMDA 57 - 150 HZ 1 G
Shock Non-Operating	15 G, 11 MS, 3 shocks/axis
Free Fall (Unpackaged)	0.1 meter

Analog Inputs

The following table contains specifications for analog inputs.

Number of Channels	2
Input Ranges	± 10 VDC
Input Type	Single-ended
Resolution	14 bit
Surge Tolerance	
Voltage Input	± 30 VDC
Over-range Tolerance	5% full scale
Protection	Polarity inversion
Common Mode Rejection	250 VAC @ 47 to 63 HZ or 250 VDC channel to ground
Cross Talk Between Channels	± lowest significant bit
Common Mode Rejection Ration @ DC	± lowest significant bit
Common Mode Rejection Ration @ 50/60	± lowest significant bit
Maximum Input Signal	15 VDC for voltage input
Filtering	Low pass with cutoff frequency 900 Hz
Conversion Times	1.6 ms maximum for 2 input channels
Sampling Period	3.2 ms per channel
Range	± 10 VDC
Input Impedance	> 2.2 MOhm
Error @ 25°C	0.2% for full scale
Error @ 60°C	0.55% for full scale
Temperature Drift @ 60°C	100ppm full scale /°C

Analog Outputs

The following table contains specifications for analog outputs.

Number of Channels	2
Output Ranges	± 10 VDC
Resolution	14 Bit
Conversion Times	1.60 ms for all channels
Output Setting Time	3.2 ms to 0.1% of final value
Accuracy	Max. error @ 25°C $\pm 0.4\%$ for -10 to +10 VDC
Linearity	± 1 LSB, Guaranteed Monotonic
Output Impedance	< 0.2 Ohms
Maximum Output Current	5 mA
Maximum Temperature Drift @ 60°C	± 100 ppm of full scale per °C
Data Format	Left justified
Crosstalk Between Channels	80 dB
Load	> 2K Ohms @ ± 10 VDC
Channel to Channel Isolation	700 VDC

Discrete Inputs

The following table contains specifications for discrete inputs.

Operating Voltage	16 to 42 VDC
Absolute Minimum Voltage	12 VDC
Absolute Maximum Voltage	45 VDC
Number of Points	16
Number of Groups	1
Points per Group	16
Type of Signal	True high (sourcing)
IEC 1131 I/O Type @ 24 VDC	1+
Minimum ON Voltage	> 11 VDC
Maximum OFF Voltage	< 5 VDC
Input Operating Current	1.2 mA and lower, off 2.5 to 10 mA, on
Input Voltage	
Range	16 to +42 VDC
Surge	75 volt peak for 10 ms
Response Time	6.2 ms OFF to ON @ 24 VDC 7.3 ms ON to OFF @ 24 VDC

Discrete Outputs

The following table contains specifications for discrete outputs.

Description	Solid state switch
Operating Voltage	16 - 42 VDC
Absolute Minimum Voltage	12 VDC
Absolute Maximum Voltage	45 VDC
Maximum Voltage	50 VDC for 1 ms
Number of Points	8
Number of Groups	1
Points per Group	8
Current Capacity	250 mA per point 2 amps per module
Type of Signal	True high (sourcing)
Leakage Current	< 1 mA @ 42 VDC
Surge Current	5 amps for 1 ms
On State Voltage Drop	< 1.0 VDC max at 0.25 amp current
Fault Sensing	Overload and short circuit
Fault Reporting	System bit
Response Time	1.8 ms OFF to ON 1.8 ms ON to OFF

	CAUTION
	<p>Discrete VDC outputs incorporate thermal shutdown and overload protection.</p> <p>The output current of a shorted output is limited to a nondestructive value. The short circuit heats the output driver, and the output will switch off. The output will switch on again if the driver leaves the over temperature condition and the user resets the output under program control. If the short circuit still exists after the output point is reset, the driver will reach the over temperature condition again and will switch off again.</p> <p>Failure to follow this precaution can result in injury or equipment damage.</p>

Physical Dimensions

The following table outlines physical dimensions for the I/O base.

Width	125 mm (4.9 in)
Depth (with no adapter)	40 mm (1.54 in)
Length	141.5 mm (5.5 in) no or one busbar 159.5 mm (6.3 in) two busbars 171.5 mm (6.75 in) three busbars
Weight	220 g (0.49 lb)

Internal Pin Connections

Overview

This section contains an illustration showing the internal connections between terminals on the I/O base and an optional busbar.

Illustration

The following illustration shows the internal connections between terminals.

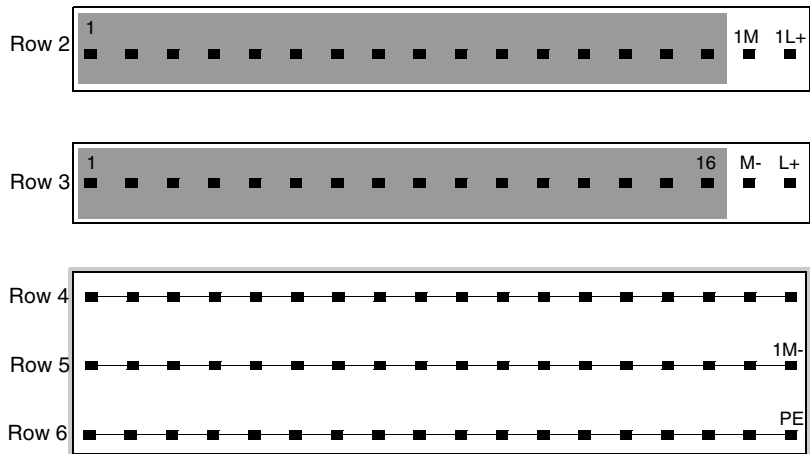

Note: AGND and DGND are connected at a single point inside the module. External digital inputs must be returned to the DGND terminal. External analog circuits must be returned to AGND terminals.

Field Wiring Guidelines

Overview

This section contains wiring guidelines and precautions for wiring the 170AMM11030 Momentum I/O base.

Terminal Connector

To connect field devices to the I/O base, you need a field wiring terminal connector. Schneider Electric sells terminal connectors in sets of three.

Type	Part Number
Screw-in	170 XTS 001 00
Spring-clip	170 XTS 002 00

Busbar May Be Required

Depending on the type of field devices you are using, you may need a 1-, 2-, or 3-row busbar. The following busbars are available from Schneider Electric.

Type	Number of Rows	Part Number
Screw-in	1 - row	170 XTS 006 01
	2 - row	170 XTS 005 01
	3 - row	170 XTS 004 01
Spring-clip	1 - row	170 XTS 007 01
	2 - row	170 XTS 008 01
	3 - row	170 XTS 003 01

Mapping Terminal Blocks and Busbars

The following table shows the mapping of terminal blocks and optional busbars.

Row #	Terminal #	Connection	Function
2	1-8	01 ... 08	Discrete outputs 1-8
	9-10	AI1, AI2	Analog inputs 1-2
	11 & 13	AO1+, AO2+	Analog outputs 1-2
	12 & 14	AO1-, AO2-	Return for analog outputs 1-2
	15	AGND	Return for analog inputs
	16		Return for discrete outputs
	17		Return for outputs
	18		+DC power for outputs
3	1-16	I1 ... I16	Discrete inputs 1-16
	17		Return
	18		+DC power
4	1-18	PE	Earth ground for field devices, PE analog ground

Wiring Diagrams

Overview

This section contains diagrams to assist you in wiring the following types of devices.

- discrete input and output
 - analog input and output
-

Discrete I/O Devices

The diagram below shows field wiring for discrete input and discrete output devices.

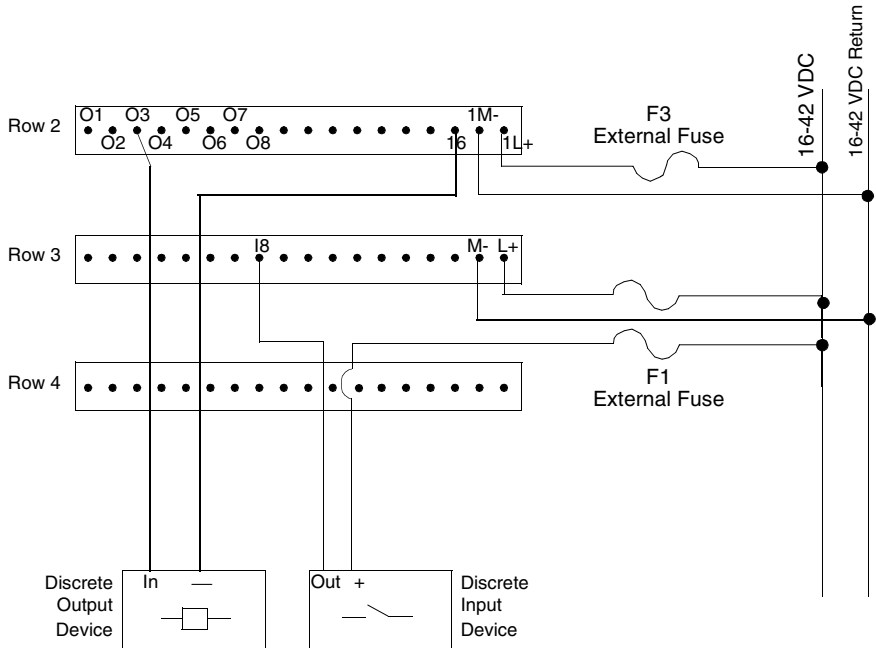

Recommended fuses:

- F1, F3: Use a 1A fuse, Wickman 19181-1A or equivalent.
 - F2: Use a 2.5A fuse, Wickman 19181-2.5A or equivalent.
-

Analog I/O Devices

The diagram below shows field wiring for analog input and analog output devices.

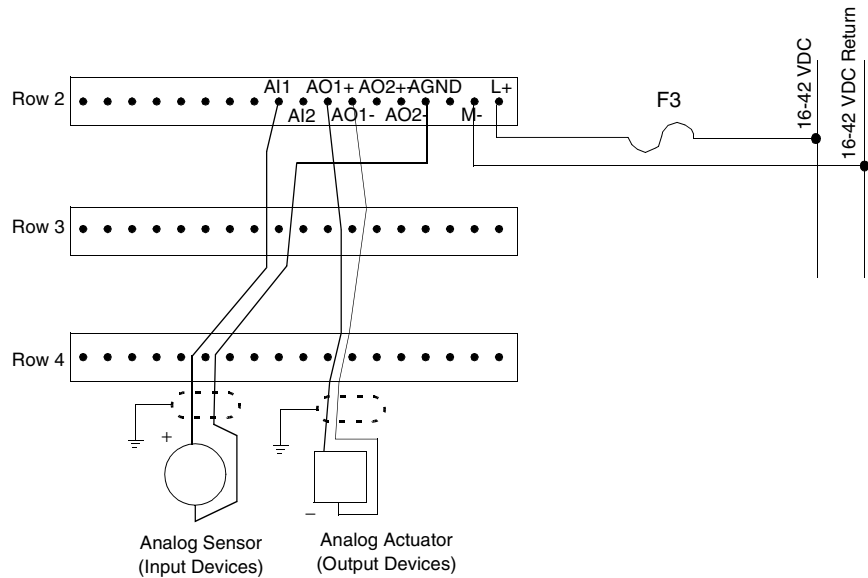

Recommended fuses:

- F3: Use a 1A fuse, Wickman 19181-1A or equivalent.

I/O Map

I/O Map Module Configuration

The module must be I/O mapped as 8 contiguous input words and 8 contiguous output words.

Range

Output Operating Range

	Output Voltage	Data is Left Justified	Comment
Output Range	-10.000 ... +10.000	00382 ... 32382	Nominal output voltage range
Output Over Range	+10.000 ... +10.238	32384 ... 32764	Linear over range output voltage
Output Out of Range	≥ 10.238	32766 (7FFE Hex)	Threshold limited to 32766 decimal
Output Under Range	-10.238 ... -10.000	00002 ... 00382	Linear under voltage range
Output Out of Range	≤ -10.238	00000	Threshold limited to 00000

Register for Inputs

Overview

The input register is arranged as follows.

Word	Function
1	Status word (module status)
2	State of the 16 discrete inputs
3	Analog input word channel 1
4	Analog input word channel 2
5 ... 8	Not used

Word 1

The status word (word 1) contains information about the health of the module and the status of the discrete outputs, including over temperature or short circuit of the discrete outputs.

Bit(s)	Description
15 ... 9	Not used
8	0 = bad module health (loss of communication to the base) 1 = healthy module)
7 (Channel 8)	0 = fault 1 = no fault
6 (Channel 7)	0 = fault 1 = no fault
5 (Channel 6)	0 = fault 1 = no fault
4 (Channel 5)	0 = fault 1 = no fault
3 (Channel 4)	0 = fault 1 = no fault
2 (Channel 3)	0 = fault 1 = no fault
1 (Channel 2)	0 = fault 1 = no fault
0 (Channel 1)	0 = fault 1 = no fault

Note: The output fault bits and the corresponding discrete output are latched OFF when a short circuit or over temperature condition is detected. To reset the fault condition and make the output operational, the output bit that faulted needs to be set to an OFF state.

Word 2

Discrete Input Register

This word contains a right justified binary 16 bit data field.

16	15	14	13	12	11	10	9	8	7	6	5	4	3	2	1
15	14	13	12	11	10	9	8	7	6	5	4	3	2	1	0

Words 3 ... 4**Analog Input Register**

Each word in this range contains a left justified 15 bit data field. The range is from 0H to 7FFE hex, but the resolution is 14 bit (0 ... 32766 decimal or 0 ... 7FFE hex).

Words 5 ... 8

Words 5 ... 8 are not used.

3x Registers

The 3x registers traffic copped to this module are used for input data as follows.

I/O Map Register	Data Type
3x + 1	Data for discrete input
3x + 2	Data for analog input channel 1
3x + 3	Data for analog input channel 2

Range

	Input Voltage	Data is Left Justified	Comment
Input Range	-10.000 ... +10.000	00382 ... 32382	Nominal input voltage range
Input Over Range	+10.000 ... +10.238	32384 ... 32764	Linear over range input voltage
Input Out of Range	≥ 10.238	32766 (7FFE Hex)	Input voltage exceeding threshold may damage the module.
Input Under Range	-10.238 ... -10.000	00002 ... 00382	Linear under voltage range
Input Out of Range	≤ -10.238	00000	Input voltage exceeding threshold may damage the module.

Analog Map

Overview

170AMM11030 analog values are mapped as follows.

Note: The display is standardized, and, in each case, the analog value will appear left justified.

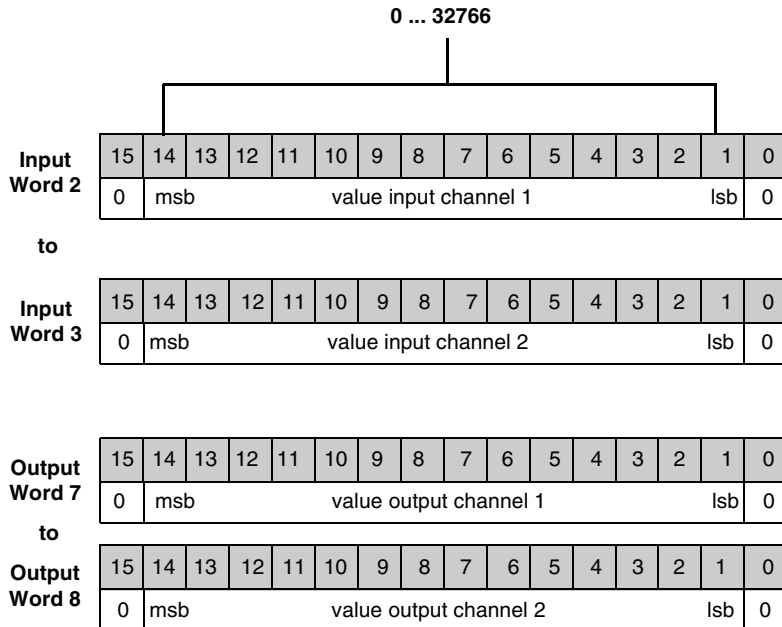

Note: The module resolution is 14-bit (0 ... 32766 decimal or 0 ... 7FFE hex).

Discrete I/O Points and IEC Compliant Data Mapping

Overview

The 170AMM11030 base returns 16 discrete input bits to the processor in one 16-bit word (3x). The input points are field wired to row 2 of the base. The processor sends 8 discrete output bits to the base as a single 16-bit word (4x). The output points are field wired to row 3.

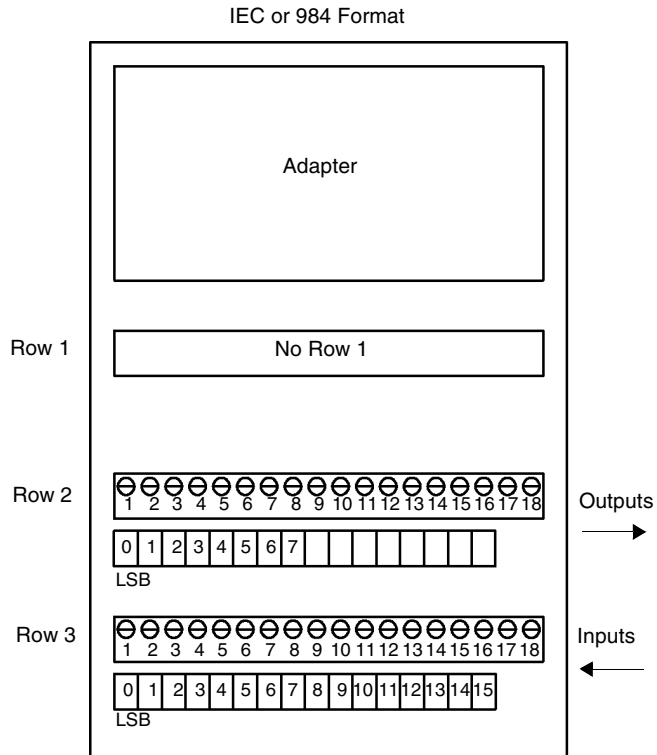

Input and Output Ranges

**Ranges and
Decimal Values
Input Measuring
Range ± 10 V**

The voltage value is calculated with the following formula using the digital measurand: $V_n = 1600 V_a + 16382$ (for the linear range).

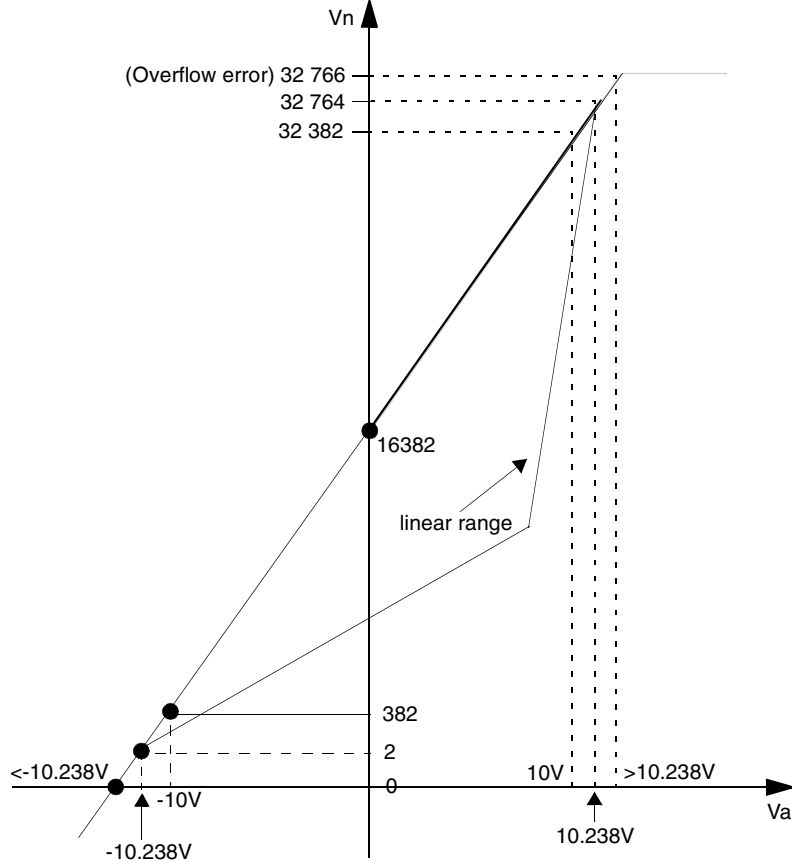

**Output
Measuring
Range ±10 V**

The voltage value is calculated with the following formula using the digital measurand: $V_n = 1600 V_a + 16382$ (for the linear range).

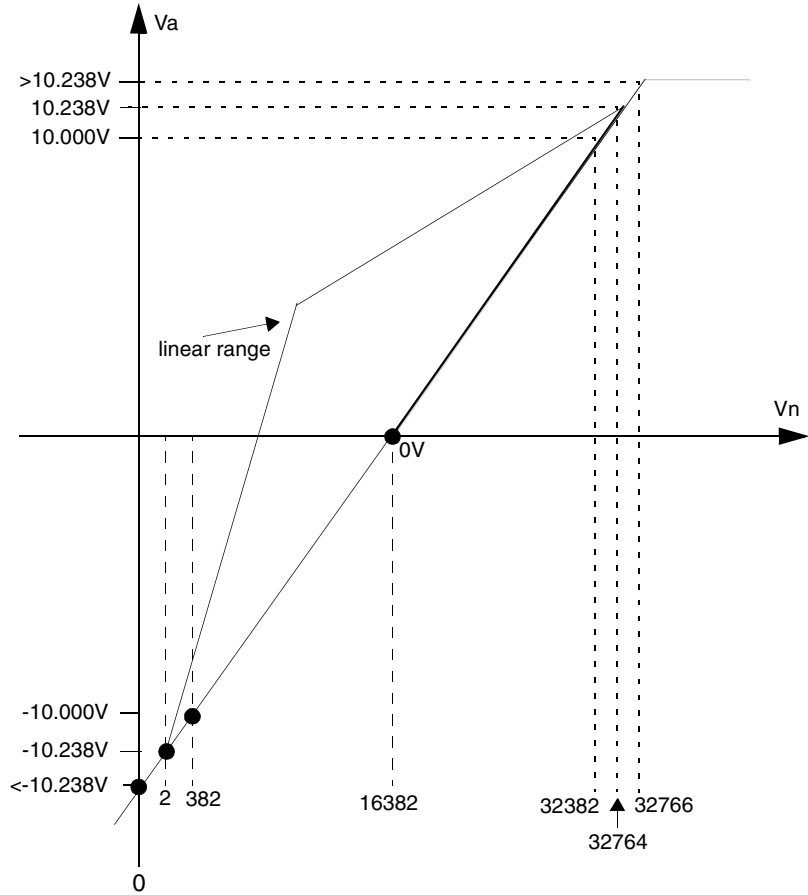

* 3 1 0 0 5 0 0 9 * 01

Visit <http://www.schneider-electric.com> for your nearest Schneider Electric affiliate.

Printed in France