

TRANSPARENT FACTORY ETHERNET CABLING SYSTEM

Quick Reference Guide

TF Switch 10/100 Mbps 8TX for ISO/DIN Rail

Order No.

499NES18100

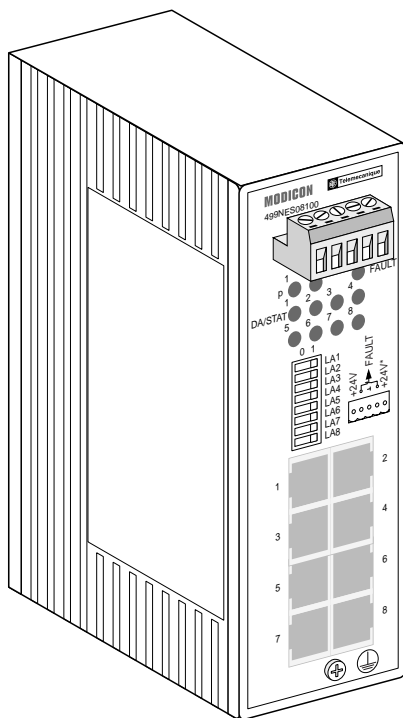

The TF Switch 8TX has been especially designed for use in industrial environments. It supports ETHERNET 10 MBit/s and Fast ETHERNET 100 MBit/s.

The TF Switch 8TX modules support switched ETHERNET networks in accordance with IEEE standard 802.3 or 802.3u using copper technology. The switch modules are plugged onto the standard bar.

The TF Switch 8TX modules have eight 10/100 MBit/s twisted pair ports (RJ45 connectors).

It is possible to connect up to eight data terminal equipments or other network segments to the 10/100 Mbit/s ports using twisted pair cabling. The ports support auto negotiation and autopolarity.

We have checked that the contents of the technical publication agree with the hardware and software described. However, it is not possible to rule out deviations completely, so we are unable to guarantee complete agreement. However, the details in the technical publication are checked regularly. Any corrections which prove necessary are contained in subsequent editions.

We are grateful for suggestions for improvement.

We reserve the right to make technical modifications.

Permission is not given for the circulation or reproduction of this document, its use or the passing on of its contents unless granted

expressly. Contravention renders the perpetrator liable for compensation for damages. All rights reserved, in particular in the case of patent grant or registration of a utility or design.

© Copyright Schneider Automation 1999
All Rights Reserved

Note

We would point out that the content of these operating instructions is not part of, nor is it intended to amend an earlier or existing agreement, permit or legal relationship. All obligations on Schneider Automation arise from the respective purchasing agreement which also contains the full warranty conditions which have

sole applicability. These contractual warranty conditions are neither extended nor restricted by comments in these operating instructions.

We would furthermore point out that for reasons of simplicity, these operating instructions cannot describe every conceivable problem associated

with the use of this equipment. Should you require further information or should particular problems occur which are not treated in sufficient detail in the operating instructions, you can request the necessary information from your Schneider Electric regional sales office.

General

Electricity is used to operate this equipment. Comply in every detail with the safety requirements specified in the operating instructions regarding the voltages to apply!



Warning

If warning notes are ignored, severe injuries and/or material damage may occur.

Only appropriately qualified staff should work on or near this equipment. Such staff must be thoroughly acquainted with

all the warnings and maintenance measures contained in these operating instructions.

The proper and safe operation of this equipment assumes proper transport, appropriate storage and assembly and careful operation and maintenance.

Staff qualification requirements

Qualified staff within the meaning of these operating instructions or the warning notes are persons familiar with setting up, assembling, starting up and operating this product and who have appropriate qualifications to cover their

activities, such as:

- training or instruction/entitlement to switch circuits and equipment/systems on and off, ground them and identify them in accordance with current safety standards;

- training or instruction in accordance with current safety standards in looking after and using appropriate safety equipment;
- first aid training.

Safety guidelines



Warning

The TF Switch 8TX units are designed for operation with safe extra-low voltage. Accordingly, only safe extra-low voltages (SELV) conforming to IEC950/EN60950/VDE0805 may be connected to the supply voltage connections.

1. Functional description

The 10/100BASE-T(X) ports of a TF Switch 8TX represent a terminal connection for the connected LAN segment. You can connect single devices or complete network segments.

1.1 FRAME-SWITCHING FUNCTIONS

Store and Forward

All data received by the TF Switch 8TX from the system bus or at the ports are stored and checked for validity. Invalid and defective frames (> 1.518 byte or CRC error) as well as fragments (< 64 byte) are discarded. The TF Switch 8TX forwards the valid frames.

Multi address capability

A TF Switch 8TX learns all source addresses per port. Only packets with
 - unknown addresses
 - addresses learnt at this port
 - a multi/broadcast address
 in the destination address field are sent to this port. A TF Switch 8TX learns up to 1,000 addresses. This becomes necessary if more than one terminal device is connected to one or more ports. In this way several independent subnetworks can be connected to an TF Switch 8TX.

Learnt addresses

A TF Switch 8TX monitors the age of the learned addresses. The TF Switch 8TX deletes address entries from the address table which exceed a certain age (30 seconds).
 Note: Restarting deletes the learned address entries.

Tagging (IEEE 802.1Q)

The IEEE 802.1 Q standard designates the VLAN tag to be included in a MAC data frame for the VLAN and prioritizing functions. The VLAN tag consists of 4 bytes. It is inserted between the source address field and the type field. Data packets with VLAN tag are transmitted unchanged by the TF Switch 8TX.

1.2 SPECIFIC FUNCTIONS OF THE TP/TX INTERFACE

Link control

The TF Switch 8TX monitors the connected TP/TX line segments for short-circuit or interrupt using regular link test pulses in accordance with IEEE standard 802.3 10/100BASE-T/TX. The TF Switch 8TX does not transmit any data to a TP/TX segment from which it does not receive a link test pulse.

Note: A non-occupied interface is assessed as a line interrupt. The TP/TX line to terminal equipment which is switched off is likewise assessed as a line interrupt as the de-energised bus coupler cannot transmit link test pulses.

Auto polarity exchange

If the receive line pair is incorrectly connected (RD+ and RD- switched) polarity is automatically reversed.

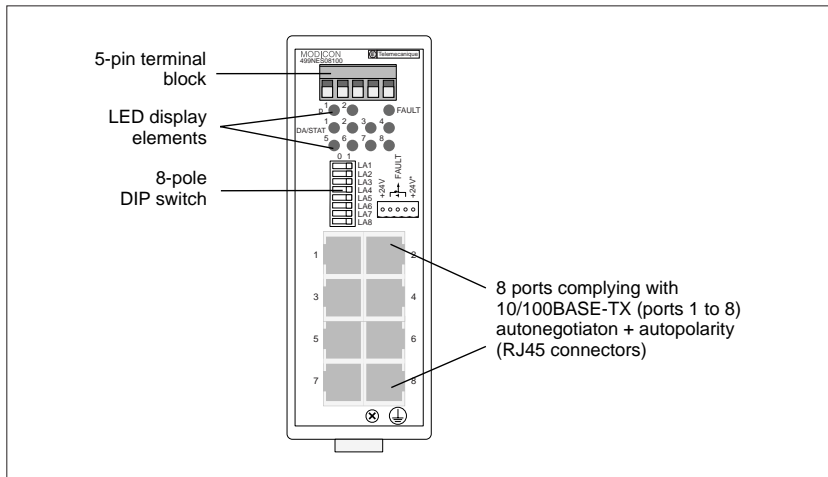

Fig. 1: Overview interfaces, display elements and controls of the TF Switch

1.3 FURTHER FUNCTIONS AND FEATURES

Reset

The TF Switch 8TX will be reset by the following action: input voltages fall below a threshold.

After a reset the following action is carried through: initialization.

1.4 DISPLAY ELEMENTS

Equipment status

These LEDs provide information about statuses which affect the function of the entire TF Switch 8TX.

P1 - Power 1 (green LED)

- lit: supply voltage 1 present
- not lit: supply voltage 1 less than 9.6 V

P2 - Power 2 (green LED)

- lit: supply voltage 2 present
- not lit: supply voltage 2 less than 9.6 V

FAULT - Failure (red LED)

- lit: The indicator contact is open, i.e. it indicates an error.
- not lit: The indicator contact is closed, i.e. it does not indicate an error.

Port Status

These LEDs display port-related information.

DA/STAT 1 to 8 – Data, Link status (green/yellow LED)

- not lit: no valid link
- lit green: valid link
- flashes yellow: receiving data

1.5 CONTROLS

8-pin DIP switch

Using the 8-pin DIP switch on the TF Switch 8TX front panel

- the message about the link statuses can be suppressed by the indicator contact on a port-by-port basis. Using switches LA1 to LA8, the message about the link status of ports 1 to 8 is suppressed. State on delivery: switch position 1 (on), i.e. message not suppressed.

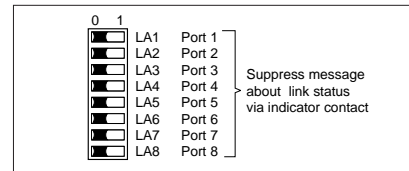

Fig. 2: 8-pin DIP switch on TF Switch 8TX

1.6 INTERFACES

10/100 Mbit/s connection

Eight 10/100 Mbit Ports (ports 1 to port 8, 8-pin RJ45 sockets) on TF Switch 8TX allow terminal equipment or eight independent network segments complying with the standards IEEE 802.3 100BASE-TX / 10BASE-T to be connected. These ports support autonegotiation and the autopolarity function.

The socket casings are electrically connected to the front panel of the TF Switch 8TX. The pin configuration complies with MDI-X.

- Pin configuration of the RJ45 socket:
 - TD+: pin 3, TD-: pin 6
 - RD+: pin 1, RD-: pin 2
 - remaining pins: not used.

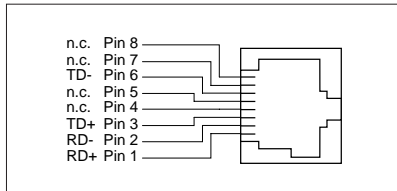

Fig. 3: Pin configuration of an TP/TX interface

5pin terminal block

The supply voltage and the indicator contact are connected via a 5pin terminal block.



The TF Switch 8TX equipment is designed for operation with SELV. Only safety extra-low voltages to IEC950/EN60950/VDE0805 may therefore be connected to the supply voltage connections and to the indicator contact.

- Voltage supply: Redundant voltage supplies are supported. Both inputs are decoupled. There is no load distribution. With redundant supply, the power pack supplies the TF Switch 8TX only with the higher output voltage. The supply voltage is electrically isolated from the housing.
- Indicator contact: The indicator contact is used to supervise the functions of the TF Switch 8TX and thus facilitates remote diagnosis without management software. Contact interrupt indicates the following by means of a potential-free indicator contact (relay contact, closed circuit):
 - the failure of at least one of the two supply voltages.
 - a permanent fault in the TF Switch 8TX (internal 3,3 V DC voltage, supply voltage 1 or 2 < 9.6 V, ...).
 - the faulty link status of at least one port. The indication of the link state on the TF Switch 8TX can be masked on a port-by-port basis using the DIP switches LA1 to LA8. State of delivery: fault not masked.

Note: In the case of the voltage supply being routed without redundancy, the TF Switch 8TX indicates the failure of a supply voltage. You can prevent this message by feeding in the supply voltage through both inputs.

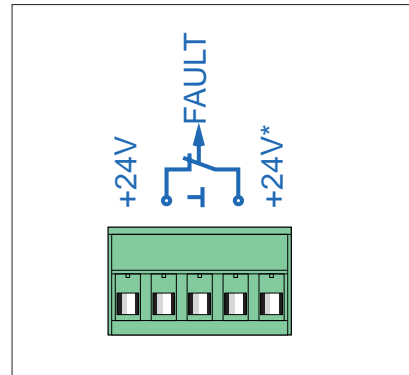

Fig. 4: Pin configuration of 5pin terminal block

Ground connection

The TF Switch 8TX is grounded via a separate screw connection.

2. Configuration

2.1 CONNECTING DTE AND OTHER NETWORK SEGMENTS

It is possible to connect up to eight data terminal equipments (DTE) or other network segments to the 10/100 Mbit/s ports of the TF Switch 8TX using twisted pair cabling (ref. Fig. 5).

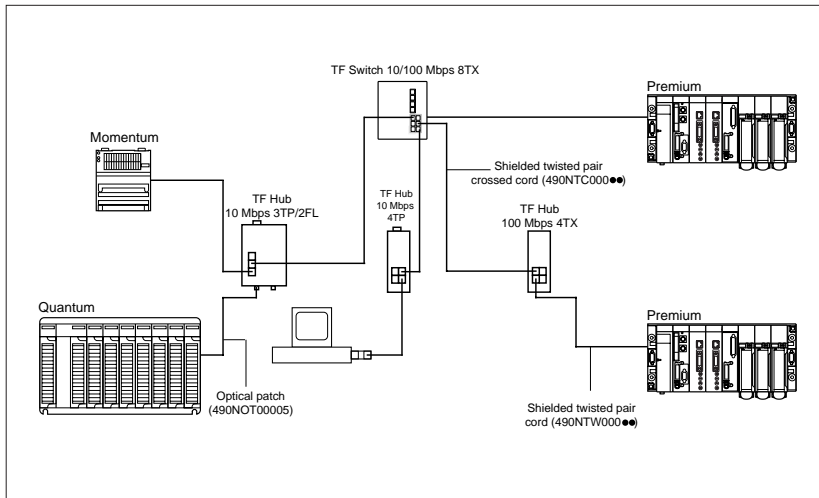

Fig. 5: Configuration with TF Switch 8TX: Connection of up to 8 data terminal equipments or further segments via TP/TX

3. Assembly, startup procedure and dismantling

3.1 UNPACKING, CHECKING

Check whether the package was delivered complete (see scope of delivery). Check the individual parts for transport damage.



Warning

Use only undamaged parts!

3.2 ASSEMBLY

The equipment is delivered in a ready-to-operate condition. The following procedure is appropriate for assembly:

Check whether the switch pre-setting suits your requirements (see chap. 1.5). Pull the terminal block off the TF Switch 8TX and wire up the supply voltage and indicator lines.

Fit the TF Switch 8TX on a 35 mm standard bar to DIN EN 50 022.

Attach the upper snap-on slide bar of the TF Switch 8TX to the standard bar and press it down until it locks in position.

Fit the signal lines.

Notes:

- The front panel of the TF Switch 8TX is grounded via a separate ground connection.
- Do not open the housing.
- The shielding ground of the twisted pair lines which can be connected is electrically connected to the front panel.

3.3 STARTUP PROCEDURE

You start up the TF Switch 8TX by connecting the supply voltage via the 5-pin terminal block.

3.4 DISMANTLING

To take the TF Switch 8TX off the ISO/DIN rail, insert a screwdriver horizontally under the housing into the locking slide, pull it (without tipping the screwdriver) downwards and lift the TF Switch 8TX upwards.

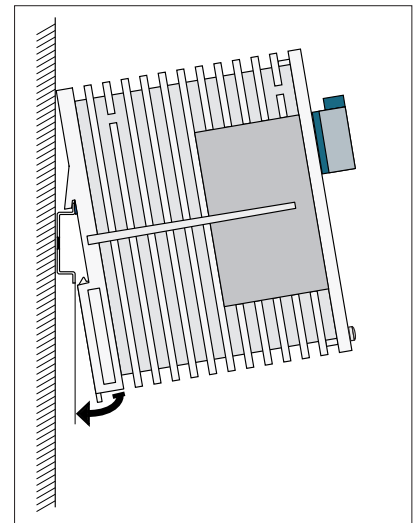

Fig. 6: Assembling the TF Switch 8TX

4. Technical data

General data

Operating voltage	DC 18 V...32 V V safety extra-low voltage (SELV) (redundant inputs decoupled)	
Current consumption	125 mA typ., at 24 VDC, no link 290 mA maximum, at 24 VDC, 8 ports full load	
Overload current protection at input	non-changeable thermal fuse	
Dimensions W x H x D	47 mm x 135 mm x 111 mm	1.9 in x 5.3 in x 4.4 in
Weight	230 g	5.07 lb
Ambient temperature	0 °C to + 60 °C	32 °F to 140 °F
Storage temperature	- 20 °C to + 80 °C	-4 °F to 176 °F
Humidity	up to 95% (not-condensing)	
Laser protection	Class 1 conform to EN 60825	
Protection class	IP 20	
Interference immunity	EN 61000-6-2:1999	
Radio interference level	EN 55022 Class A Warning! This is a Class A Equipment. This equipment may cause radio interference if used in a residential area; in this case it is the operator's responsibility to take appropriate measures.	
Agency Approval	IEC 61131-2, Marine (Germanisher Lloyd)	

Network size

TP/TX port 10BASE-T/100BASE-TX	
Length of a twisted pair segment	100 m (328 ft) maximum

Interfaces

8 TP/TX ports	RJ45 sockets, 10/100 Mbps
Indicator contact	1 A maximum, 24 V

Displays

Equipment status	1 x green LED 1 x green LED 1 x red LED	P1 - power 1, supply voltage 1 present P2 - power 2, supply voltage 2 present FAULT - indicator contact is open and indicates error
Port status	8 x green/yellow LED	1 to 8 - data, link status

Controls

8-pole DIP switch	LA1 to LA8 - suppress message about the link statuses
-------------------	---

Scope of delivery

TF Switch 10/100 Mbps 8TX includes terminal block for supply voltage Quick reference guide	
Order number TF Switch 10/100 Mbps 8TX	499NES18100

Accessories

TF Ethernet SFTP cat5RJ45 cords	490NTW000●●
TF Ethernet SFTP cat5RJ45 crossed cords	490NTC000●●
Transparent Factory User and Planning Guide	490USE13300
Transparent Factory Network Design and Cabling Guide	490USE13400



Notes on CE identification

The devices comply with the regulations of the following European directive:

89/336/EEC

Council Directive on the harmonisation of the legal regulations of member states on electromagnetic compatibility (amended by Directives 91/263/EEC, 92/31/EEC and 93/68/EEC).

Area used	Requirements for emitted interference	interference immunity
Industrial	EN 50081-2: 1993 EN 55022 Class A: 1998	EN 61000-6-2:1999

The product can be used in the residential sphere (residential sphere, business and trade sphere and small companies) and in the industrial sphere.

The precondition for compliance with EMC limit values is strict adherence to the construction guidelines specified in this description and operating instructions.



* 3 5 0 0 4 2 5 5 K 0 2 0 0 0 * 00