

## ALTIVAR® 11

### Adjustable Speed Drive Controllers Start-up Guide

### Guía de puesta en marcha de los variadores de velocidad ajustable

### Guide de mise en service des variateurs de vitesse

Retain for future use.  
Conservar para uso futuro.  
À conserver pour usage ultérieur.



ENGLISH

ESPAÑOL

FRANÇAIS



## SETTING UP THE ALTIVAR 11 DRIVE CONTROLLER

Read and follow these instructions before beginning any procedure with this drive controller.

### **DANGER**

#### **HAZARDOUS VOLTAGE**

- Read and understand this start-up guide before installing or operating the ALTIVAR 11 drive controllers. Installation, adjustment, repair, and maintenance must be performed by qualified personnel.
- For more information on ALTIVAR 11 drive controllers, see instruction bulletin VVDED302026US, available from [www.SquareD.com](http://www.SquareD.com) or from your Schneider Electric representative.
- The user is responsible for conforming to all applicable code requirements with respect to grounding all equipment.
- Many parts in this drive controller, including printed wiring boards, operate at line voltage. **DO NOT TOUCH.** Use only electrically insulated tools.
- **DO NOT** touch unshielded components or terminal strip screw connections with voltage present.
- **DO NOT** short across terminals PA and PC or across the DC capacitors.
- Install and close all covers before applying power or starting and stopping the drive controller.
- Before servicing the drive controller:
  - Disconnect all power.
  - Place a “DO NOT TURN ON” label on the drive controller disconnect.
  - Lock the disconnect in the open position.
- Disconnect all power including external control power that may be present before servicing the drive controller. **WAIT 15 MINUTES** for the DC bus capacitors to discharge. Then follow the DC bus voltage measurement procedure beginning on page 5 to verify that the DC voltage is less than 45 Vdc. The drive controller LEDs are not accurate indicators of the absence of DC bus voltage.

**Electric shock will result in death or serious injury.**

### **CAUTION**

#### **DAMAGED EQUIPMENT**

Do not operate or install any drive controller that appears damaged.

**Failure to follow this instruction can result in injury or equipment damage.**

1. Mount the drive controller (pages 4–5).
2. With the power removed, make the following connections to the drive controller (pages 5–8):
  - Connect the grounding conductors.
  - Connect the line supply. Ensure that it is within the voltage range of the drive controller.
  - Connect the motor. Ensure that its rating corresponds to the drive controller’s voltage.
3. Power up the drive controller, but do not give a run command.
4. Configure the following first level adjustment parameters (pages 9–10):
  - bFr (motor nominal frequency), if it is other than 60 Hz. bFr only appears as a first level adjustment parameter the first time the drive controller is powered up.
  - ACC (acceleration) and dEC (deceleration)
  - LSP (low speed when the reference is zero) and HSP (high speed when the reference is at maximum)
  - ItH (motor thermal protection)
  - Preset speeds: SP2, SP3, SP4.
  - Speed reference, if it is other than 0–5 V (0–10 V, 0–20 mA, 4–20 mA).
5. If the factory configuration is not suitable for the application, configure the parameters and I/O assignments in the drC and FUn menus. Refer to the tables beginning on page 10 for the factory configuration.
6. Remove power from the drive controller, then connect the control wiring via the logic and analog inputs.
7. Power up the drive controller, then issue a run command via the logic input (page 12).

**DIMENSIONS**

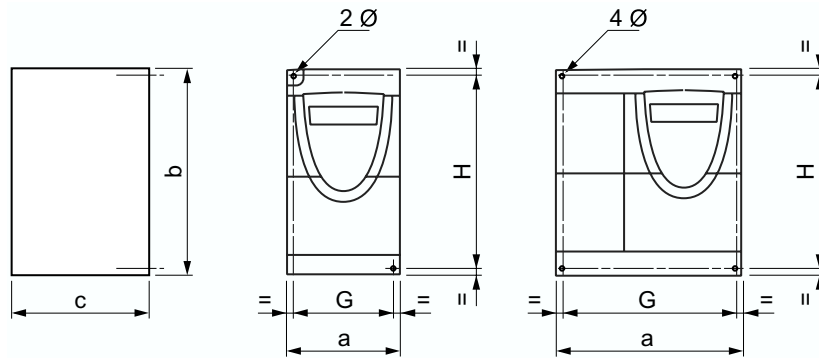

	a		b		C		G		H		Ø	
	in.	mm	in.	mm	in.	mm	in.	mm	in.	mm	in.	mm
<b>ATV11H</b> •••••												
U05••U	2.9	72	5.7	142	4.0	101	2.4	60	5.2	131	2 x 0.2	2 x 5
U09••U					5.0	125						
U18M•U	2.9	72	5.9	147	5.5	138	2.4	60	5.2	131	2 x 0.2	2 x 5
U18F1U												
U29••U U41••U	4.7	117	5.7	142	6.2	156	4.2	106	5.2	131	4 x 0.2	4 x 5
<b>ATV11P</b>												
All ratings	2.9	72	5.7	142	4.0	101	2.4	60	5.2	131	2 x 0.2	2 x 5

## MOUNTING AND TEMPERATURE CONDITIONS

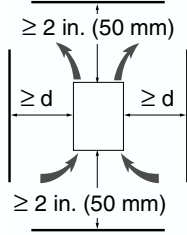

Install the drive controller vertically  $\pm 10^\circ$  with the output terminals at the bottom.

Do not place the drive controller close to heating sources.

Leave sufficient free space around the drive controller to ensure that air can circulate from the bottom to the top of the unit.

Leave a minimum of 0.4 in. (10 mm) of free space in front of the drive controller.

14 to 104 °F  
(-10 to 40 °C):

- $d \geq 2$  in. (50 mm): no special precautions.
- $d = 0$  (side-by-side drive controllers): remove the protective cover.

104 to 122 °F  
(40 to 50 °C):

- $d \geq 2$  in. (50 mm): remove the protective cover.

122 to 140 °F  
(50 to 60 °C):

- $d \geq 2$  in. (50 mm): remove the protective cover and derate the drive nominal current by 2.2% for every °C above 50°C.

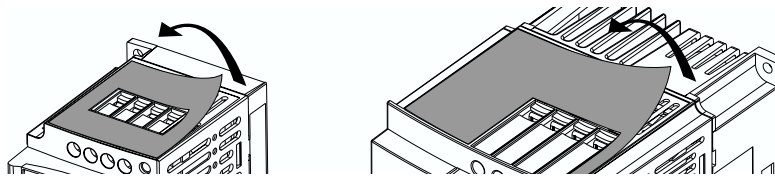

**NOTE:** Monitor the *tHd* parameter (in the SUP menu) during normal operation to verify the drive controller thermal state.

Refer to instruction bulletin VVDED302026US for information on mounting ATV11P drive controllers.

## BUS VOLTAGE MEASUREMENT PROCEDURE

### **⚠ DANGER**

#### **HAZARDOUS VOLTAGE**

Read and understand the precautions on page 3 before performing this procedure.

**Failure to follow these instructions will result in death or serious injury.**

The bus voltage can exceed 400 Vdc. Use appropriately rated measuring equipment when performing this procedure. To measure the bus capacitor voltage:

1. Disconnect all power from the drive controller.
2. Wait 15 minutes to allow the DC bus to discharge.
3. Measure the DC bus voltage between the PA (+) and PC (–) terminals to verify that the DC voltage is less than 45 Vdc. Refer to “Power Terminals” on page 8 for the location of the terminals.
4. If the bus capacitors are not fully discharged, contact your local Schneider Electric representative—do not operate the drive controller.

## ELECTRICAL INSTALLATION

Ensure that the electrical installation of this drive controller conforms to the appropriate national and local codes.

- Verify that the voltage and frequency of the input supply line and the voltage, frequency, and current of the motor match the rating on the drive controller nameplate.

### **⚠ DANGER**

#### **HAZARDOUS VOLTAGE**

Ground equipment using the provided ground connecting point as shown in the figure below. The drive controller panel must be properly grounded before power is applied.

**Electric shock will result in death or serious injury.**

- Verify that resistance to ground is one ohm or less. Ground multiple controllers as shown in the figure. Do not loop the ground cables or connect them in series.

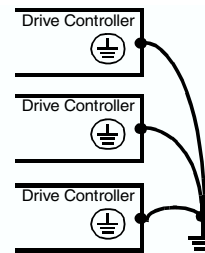

- Provide overcurrent protection. To achieve the fault-withstand current rating listed on the drive controller nameplate, install the line power fuses recommended on the drive controller nameplate.

### **⚠ WARNING**

#### **INADEQUATE OVERCURRENT PROTECTION**

- Overcurrent protective devices must be properly coordinated.
- The National Electrical Code requires branch circuit protection. Use the fuses recommended on the drive controller nameplate to achieve published fault withstand current ratings.
- Do not connect the drive controller to a power feeder whose short circuit capacity exceeds the drive controller withstand fault rating listed on the drive controller nameplate.

**Failure to follow these instructions can result in death, serious injury, or equipment damage.**

- Do not use mineral-impregnated cables. Select motor cabling with low phase-to-phase and phase-to-ground capacitance.
- Motor cables must be at least 20 in. (0.5 m) long.
- Maximum motor cable length is 50 m (164 ft.) for shielded cable and 100 m (328 ft.) for non-shielded cable. Verify that the motor is designed for use with AC drive controllers. Cable runs longer than 12.2 m (40 ft.) may require output filters to reduce voltage spikes at the motor terminals.
- Do not run control, power, or motor wiring in the same conduit. Do not run motor wiring from different drive controllers in the same conduit. Separate metallic conduit carrying power wiring from metallic conduit carrying control wiring by at least 3 in. (8 cm). Separate non-

metallic conduits or cable trays used to carry power wiring from metallic conduit carrying control wiring by at least 12 in. (31 cm). Always cross power and control wiring at right angles.

## ⚠ WARNING

### IMPROPER WIRING CONNECTIONS

- The drive controller will be damaged if input line voltage is applied to the output terminals (U, V, W).
- Check the power connections before energizing the drive controller.
- If replacing another drive controller, verify that all wiring connections to the ATV11 drive controller comply with all wiring instructions in this manual.

**Failure to follow these instructions can result in death, serious injury, or equipment damage.**

- Do not immerse motor cables in water.
- Do not use lightning arrestors or power factor correction capacitors on the output of the drive controller.
- Equip all inductive circuits near the drive controller (such as relays, contactors, and solenoid valves) with electrical noise suppressors, or connect them to a separate circuit.

## WIRING DIAGRAM FOR FACTORY SETTINGS

Single phase line supply 100–120 V

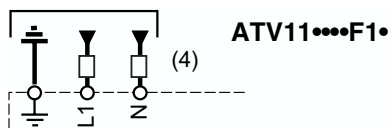

Single phase line supply 200–230 V

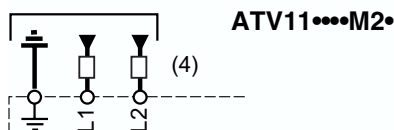

3-phase line supply 200–240 V

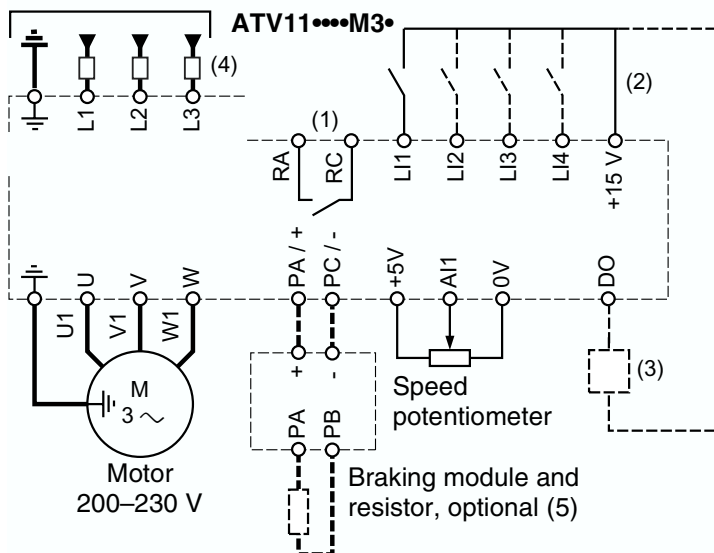

*NOTE: The line supply terminals are shown at the top and the motor terminals are shown at the bottom. Connect the power terminals before connecting the control terminals. Install surge suppressors on all inductive circuits located near the drive controller or coupled to the same circuit.*

- (1) Fault relay contacts for remote indication of drive controller status.
- (2) Internal + 15 V. If an external source is used (30 V Max.), connect the 0 V of the source to the 0 V terminal, and do not use the + 15 V terminal on the drive controller.
- (3) Meter or low level relay.
- (4) Refer to drive controller nameplate for recommended fuses. Fast acting or time delay Class J fuses can be used.
- (5) See bulletin VVDED302026US for precautions and additional information concerning dynamic braking.

**POWER TERMINALS**

ATV11.....	Maximum Connection Capacity		Tightening Torque	
	AWG	mm <sup>2</sup>	lb-in	N•m
U05..., U09..., U18M...	AWG 14	1.5	6.6	0.75
U18F1•, U29..., U41...	AWG 10	4	8.9	1

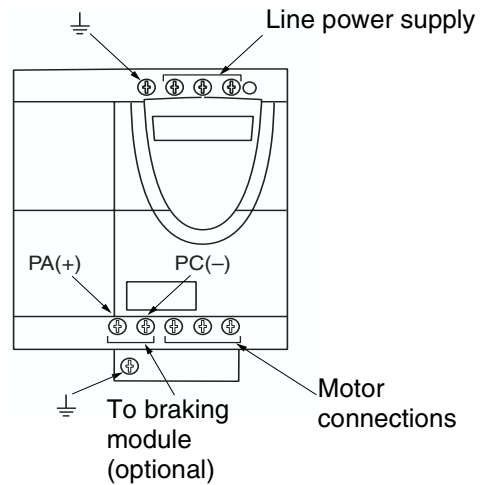
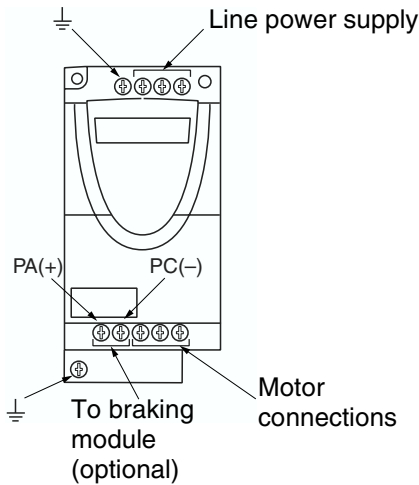

**CONTROL TERMINALS**

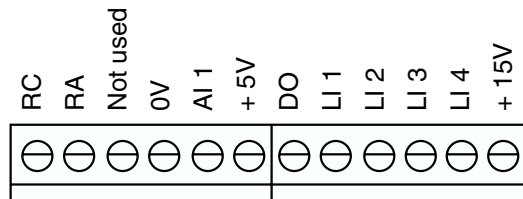
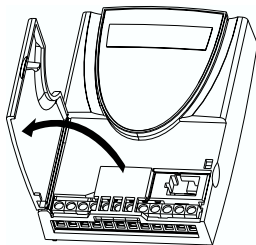

Maximum connection capacity:  
AWG 16 (1.5 mm<sup>2</sup>)  
Maximum tightening torque:  
4.4 lb-in (0.5 N•m).

Terminal	Function	Electrical Characteristics
RC RA	Fault relay contact (open if there is a fault or the drive controller is off)	Min. switching capacity: 10 mA for 24 Vdc Max. switching capacity: • 2 A for 250 Vac and 30 Vdc on inductive load Time constant = 0.4 – (inductance/resistance) = 7 ms • 5 A for 250 Vac and 30 Vdc on resistive load Time constant = 1– (inductance/resistance) = 0
0 V	I/O common	0 V
AI1	Voltage or current analog input	Analog input 0–5 V or 0–10 V: impedance 40 kΩ, 30 V max. Analog input 0–20 mA or 4–20 mA: impedance 250 Ω (with no external resistor)
+5 V	Power supply for reference potentiometer 2.2 to 10 kΩ	• Precision: 0–5% • Max. current available: 10 mA

Terminal	Function	Electrical Characteristics
DO	Output (can be configured as analog or logic output)	PWM open collector analog output at 2 kHz: • voltage 30 V max., impedance 1 kΩ, 10 mA max. Open collector logic output: • voltage 30 V max., impedance 100 kΩ, 50 mA max.
LI1 LI2 LI3 LI4	Programmable logic inputs	• Power supply + 15 V (max. 30 V), Impedance 5 kΩ • State 0 if < 5 V, state 1 if > 11 V
+ 15 V	Logic input power supply	+ 15 V ± 15% (protected against short circuits and overloads) Maximum current available: 100 mA

### PROGRAMMING THE DRIVE CONTROLLER

Exits a menu or parameter, or aborts the displayed value and returns to the previous value in the memory

Returns to the previous menu or parameter, or increases the displayed value

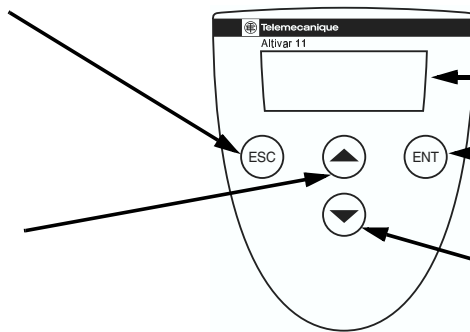

Three 7-segment displays

Enters a menu or a parameter, or saves the displayed parameter or value

Goes to the next menu or parameter, or decreases the displayed value

- Pressing or does not save the choice.
- To save the displayed choice, press .

### PROGRAMMING EXAMPLE

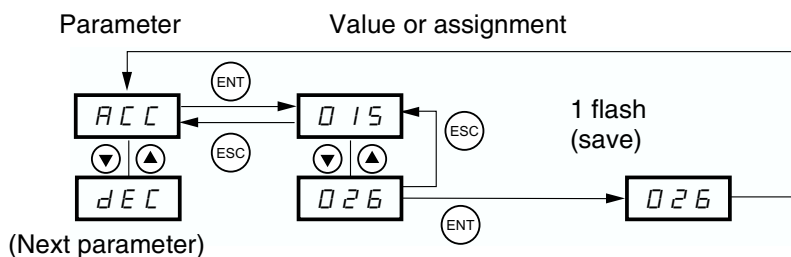

The display flashes when a value is stored.

Normal display with no fault present and no run command:

- rdY: Drive controller ready
- 43.0: Display of the parameter selected in the SUP menu (default selection: reference frequency)
- dcb: DC injection braking in progress
- nSt: Freewheel stop

If there is a fault, the display flashes.

ENGLISH

FIRST LEVEL ADJUSTMENT PARAMETERS

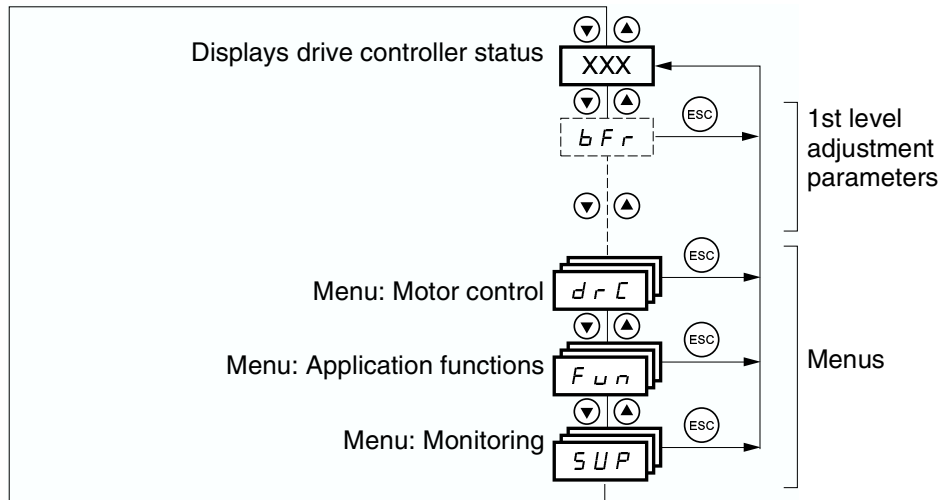

The parameters in unshaded boxes can only be modified when the controller is stopped and locked.

The parameters in shaded boxes can be modified with the controller operating or stopped.

Code	Description	Adjustment range	Factory setting
bFr	Motor frequency	50 or 60 Hz	60
	This parameter is only displayed here the first time the drive controller is powered up. It can be modified at any time in the FUn menu.		
drC	Acceleration ramp time	0.1 s to 99.9 s	3
	Range: 0 Hz to motor nominal frequency FrS (parameter in drC menu).		
deC	Deceleration ramp time	0.1 s to 99.9 s	3
	Range: motor nominal frequency FrS (parameter in drC menu) to 0 Hz.		
LSP	Low speed	0 Hz to HSP	0
HSP	High speed	LSP to 200 Hz	= bFr
	Ensure that this setting is appropriate for the motor and the application.		
ItH	Motor thermal current	0 to 1.5 In <sup>[1]</sup>	According to rating
	Current used for motor thermal protection. Set ItH to the nominal current on the motor nameplate. <i>NOTE: The motor thermal state memory is reset to zero when the drive controller is powered down.</i>		
SP2	2 <sup>nd</sup> preset speed <sup>[2]</sup>	0.0 to 200 Hz	10
SP3	3 <sup>rd</sup> preset speed <sup>[2]</sup>	0.0 to 200 Hz	25
SP4	4 <sup>th</sup> preset speed <sup>[2]</sup>	0.0 to 200 Hz	50
RIE	Configuration of the analog input	5 V, 10 V, 0 mA, 4 mA	5 V
	- 5U: voltage, 0–5 V (internal power supply) - 10U: voltage, 0–10 V (external power supply) - 0A: current, 0–20 mA - 4A: current, 4–20 mA		

[1] In = nominal drive controller current

[2] Appears only if the corresponding function remains at the factory setting or has been reconfigured in the FUn menu. Although preset speed assignments can be made below LSP and above HSP, LSP and HSP take precedence over the preset speed settings.

## ⚠ CAUTION

### MOTOR OVERHEATING

- This drive controller does not provide direct thermal protection for the motor.
- Use of a thermal sensor in the motor may be required for protection at all speeds or loading conditions.
- Consult the motor manufacturer for the thermal capability of the motor when operated over the desired speed range.

**Failure to follow these instructions can result in injury, or equipment damage.**

### MOTOR CONTROL MENU DRC

Code	Description	Adjustment range	Factory setting
<i>U n S</i>	Nominal motor voltage marked on the nameplate.	100 to 500 V	According to rating
<i>F r S</i>	Nominal motor frequency marked on the nameplate.	40 to 200 Hz	50/60 Hz depending on bFr
<i>S E R</i>	Frequency loop stability	0 to 100% stopped 1 to 100% operating	20
	Value too high: extension of response time Value too low: speed exceeded, possible instability.		
<i>F L G</i>	Frequency loop gain	0 to 100% stopped 1 to 100% operating	20
	Value too high: speed exceeded, instability. Value too low: extension of response time		
<i>U F r</i>	IR compensation Used to optimize the torque at very low speed, or to adapt the torque to special applications (for ex., motors connected in parallel require lower UFr).	0 to 200%	50
<i>n I r</i>	Nominal motor current marked on the nameplate	0.25 to 1.5 In	According to rating
<i>L L I</i>	Limiting current	0.5 to 1.5 In	1.5 In
<i>n S L</i>	Nominal motor slip	0 to 10.0 Hz	According to rating
	Calculate using the formula: $nSL = \text{parameter FrS} \times (1 - Nn/Ns)$ Nn = nominal motor speed marked on the nameplate Ns = motor synchronous speed		
<i>S L P</i>	Slip compensation	0 to 150% of nSL	100
	Used to adjust the slip compensation around the value set by the nominal motor slip nSL, or to adapt the slip compensation to special applications (for example, motors connected in parallel require lower SLP).		
<i>L D S</i>	Nominal motor power factor marked on the nameplate	0.50 to 1.00	According to rating

APPLICATION FUNCTIONS MENU FUn

NOTE: Multiple functions can be assigned to a single logic input and function simultaneously. If a FWD and REV are assigned to the same logic input, FWD takes precedence.

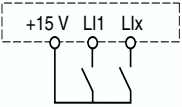
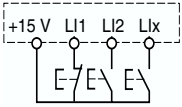
Code	Description	Factory setting
<p>tCC</p> <p>ACL</p>	<p><b>Type of control</b></p> <p>2C = 2-wire control</p> <p>3C = 3-wire control</p> <p>2-wire control: The state of the input, open or closed (1 or 0), controls running or stopping.</p> <p>Example of wiring:</p>  <p>L1: forward</p> <p>Lx: reverse</p> <p>3-wire control (pulse control): a forward or reverse pulse is sufficient for a start command; a stop pulse is sufficient for a stop command.</p> <p>Example of wiring:</p>  <p>L1: stop</p> <p>L2: forward</p> <p>Lx: reverse</p> <p>NOTE: To change the assignment of tCC, press the <b>ENT</b> key for 2 s. This causes the following functions to return to factory setting: rrS, tCt, Atr, PS2 (LIA, Lib).</p>	2C
<p>tCC</p>	<p><b>Type of 2-wire control</b> (parameter can only be accessed if tCC = 2C):</p> <p>LEL: The state of the input, open or closed (0 or 1), is taken into account when running or stopping. The input must be closed (state 1) for the drive controller to accept a run command.</p> <p>ERN: To prevent accidental restarts after a power supply interruption, a change of state (transition or edge) is necessary to initiate operation.</p> <p>PFQ: same as LEL, but the forward input always takes priority over the reverse input.</p>	trn
<p>rrS</p>	<p><b>Reverse</b></p> <p>nQ: function inactive</p> <p>L11 to L14: selects the input assigned to the reverse command</p>	<p>if tCC = 2C: LI2</p> <p>if tCC = 3C: LI3</p>

Code	Description	Factory setting
<i>P 5 2</i>	<b>Preset speeds</b> If LIA and LIb = 0: speed = reference on AI1 If LIA = 1 and LIb = 0: speed = SP2 If LIA = 0 and LIb = 1: speed = SP3 If LIA = 1 and LIb = 1: speed = SP4	
<i>L 1 A</i>	Assignment of input LIA - <i>n 0</i> : function inactive - <i>L 1 1</i> to <i>L 1 4</i> : selects the input assigned to LIA	if tCC = 2C: LI3 if tCC = 3C: LI4
<i>L 1 b</i>	Assignment of input LIb - <i>n 0</i> : function inactive - <i>L 1 1</i> to <i>L 1 4</i> : selects the input assigned to LIb SP2 is accessible only if LIA is assigned; SP3 and SP4 are accessible only if LIA and LIb are assigned.	if tCC = 2C: LI4 if tCC = 3C: nO
<i>S P 2</i>	2 <sup>nd</sup> preset speed, adjustable from 0.0 to 200 Hz	10
<i>S P 3</i>	3 <sup>rd</sup> preset speed, adjustable from 0.0 to 200 Hz	25
<i>S P 4</i>	4 <sup>th</sup> preset speed, adjustable from 0.0 to 200 Hz	50
<i>r 5 F</i>	<b>Fault reset</b> - <i>n 0</i> : function inactive - <i>L 1 1</i> to <i>L 1 4</i> : selects the input assigned to this function The fault reset occurs when the input changes state on the rising edge (0 to 1). The fault is reset only if the cause of the fault is no longer present.	nO
<i>r P 2</i>	<b>Second ramp</b>	
<i>L 1</i>	Assignment of the 2nd ramp control input - <i>n 0</i> : function inactive - <i>L 1 1</i> to <i>L 1 4</i> : selects the input assigned to the function. AC2 and dE2 are accessible only if LI is assigned.	nO
<i>A C 2</i>	2nd acceleration ramp time, adjustable from 0.1 to 99.9 s	5.0
<i>d E 2</i>	2nd deceleration ramp time, adjustable from 0.1 to 99.9 s	5.0
<i>S E P</i>	<b>Controlled stop on loss of line supply</b> - <i>n 0</i> : function inactive, motor freewheels - <i>F r P</i> : stop according the valid ramp (dEC or dE2) - <i>F 5 E</i> : fast stop, the stopping time depends on the inertia of the load and the braking capability of the drive controller.	nO
<i>b r A</i>	<b>Deceleration ramp adaptation</b> - <i>n 0</i> : function inactive - <i>Y E 5</i> : This function automatically increases the deceleration time if it has been set too low for the inertia of the load, thus avoiding an overvoltage fault.	YES
<i>A d C</i>	<b>Automatic DC injection</b> Operating mode - <i>n 0</i> : function inactive - <i>Y E 5</i> : DC injection on stopping when motor speed is zero. The injection time is adjustable via tdC. The injection current is adjustable via SdC. - <i>C E</i> : Continuous DC injection on stopping when motor speed is zero. The value of this current can be adjusted via SdC. In 3-wire control, the injection is active only when LI1 is at 1.	YES

ENGLISH

Code	Description	Factory setting
<i>t d C</i> <i>S d C</i>	<p>Injection time on stopping, adjustable from 0.1 to 30.0 s. Accessible only if ACt = YES.</p> <p>Injection current, adjustable from 0 to 1.5 In. Accessible only if ACt = YES or Ct.</p> <div style="border: 1px solid black; padding: 5px; text-align: center;"> <p><b>⚠ WARNING</b></p> <p><b>NO HOLDING TORQUE</b></p> <ul style="list-style-type: none"> <li>DC injection braking does not provide holding torque at zero speed.</li> <li>DC injection braking does not function during loss of power or during a drive controller fault.</li> <li>When required, use a separate brake for holding torque.</li> </ul> <hr/> <p><b>EXCESSIVE DC INJECTION BRAKING</b></p> <ul style="list-style-type: none"> <li>Application of DC injection braking for long periods of time can cause motor overheating and damage.</li> <li>Protect the motor from extended periods of DC injection braking.</li> </ul> <p><b>Failure to follow these instructions can result in death, serious injury, or equipment damage.</b></p> </div>	0.5 0.7 In
<i>S F t</i> <i>R C t</i>	<p><b>Switching frequency</b></p> <p>Frequency range</p> <ul style="list-style-type: none"> <li>- <i>L F r</i>: random frequency around 2 or 4 kHz according to SFr</li> <li>- <i>L F</i>: fixed frequency of 2 or 4 kHz according to SFr</li> <li>- <i>H F</i>: fixed frequency of 8, 12 or 16 kHz according to SFr</li> </ul>	LF
<i>S F r</i>	<p>Switching frequency:</p> <ul style="list-style-type: none"> <li>- <i>2</i>: 2 kHz (if ACt = LF or LFr)</li> <li>- <i>4</i>: 4 kHz (if ACt = LF or LFr)</li> <li>- <i>8</i>: 8 kHz (if ACt = HF)</li> <li>- <i>12</i>: 12 kHz (if ACt = HF)</li> <li>- <i>16</i>: 16 kHz (if ACt = HF)</li> </ul> <p>When SFr = 2 kHz, the frequency automatically changes to 4 kHz at high speed.</p> <p>When SFr = HF, the selected frequency automatically changes to the lower frequency if the thermal state of the drive controller is too high. It automatically returns to the SFr frequency as soon as the thermal state permits.</p>	4 (if ACt = LF or LFr) 12 (if ACt = HF)
<i>F L r</i>	<p><b>Catch on the fly</b></p> <p>Enables a smooth restart if the run command is maintained after the following events:</p> <ul style="list-style-type: none"> <li>- loss of line supply or removal of power</li> <li>- fault reset or automatic restart</li> <li>- freewheel stop</li> </ul> <p>The motor resumes from the estimated speed at the time of the restart, then follows the ramp to the reference speed.</p> <p>This function requires 2-wire control (tCC = 2C) with tCt = LEL or PFO.</p> <p><i>r □</i>: function inactive <i>Y E 5</i>: function active</p> <p>This function intervenes at each run command, resulting in a start after a delay of 1 second maximum.</p> <p>If continuous automatic injection braking has been configured (Ct) this function cannot be activated.</p>	nO

Code	Description	Factory setting
<p>d 0</p> <p>R C t</p> <p>F t d</p> <p>C t d</p>	<p><b>Analog/logic output DO</b> Assignment</p> <ul style="list-style-type: none"> <li>- n 0: not assigned</li> <li>- 0 C r: output/motor current (analog output). The full signal corresponds to 200% of the nominal drive controller current.</li> <li>- r F r: motor frequency (analog output). The full signal corresponds to 100% HSP.</li> <li>- F t A: frequency threshold attained (logic output), closed (state 1) if the motor frequency exceeds the adjustable threshold Ftd.</li> <li>- S r A: reference attained (logic output), closed (state 1) if the motor frequency is equal to the reference.</li> <li>- C t A: current threshold attained (logic output), closed (state 1) if the motor current exceeds the adjustable threshold Ctd.</li> </ul> <p>Ftd is accessible only if ACt = FtA. Ctd is accessible only if ACt = CtA.</p> <p>frequency threshold, adjustable from 0 to 200 Hz</p> <p>current threshold, adjustable from 0 to 1.5 In.</p>	<p>rFr</p> <p>= bFr In</p>
<p>R E r</p>	<p><b>Automatic restart</b></p> <ul style="list-style-type: none"> <li>- n 0: function inactive</li> <li>- Y E 5: Allows automatic restart after locking on a fault, if the fault has been cleared and the other operating conditions permit the restart. The restart is performed by a series of automatic attempts separated by increasingly long waiting periods: 1 s, 5 s, 10 s, then 1 min for the following periods. If the restart has not taken place after 6 min, the procedure is aborted and the drive controller remains in a fault state until the power is cycled.</li> </ul> <p>The following faults permit this function: OHF, OLF, ObF, OSF, PHF. The drive controller fault relay remains activated if this function is active. The speed reference and the operating direction must be maintained.</p> <p>This function is only accessible in 2-wire control (tCC = 2C) with tCt = LEL or PFO.</p> <div style="border: 1px solid black; padding: 10px; margin-top: 10px;"> <p style="text-align: center;"><b>⚠ WARNING</b></p> <p><b>UNINTENDED EQUIPMENT OPERATION</b></p> <ul style="list-style-type: none"> <li>Automatic restart can only be used for machines or installations that present no danger to personnel or equipment in the event of automatic restarting.</li> <li>If Automatic restart is active, R1 will only indicate a fault after the restart sequence has timed out.</li> <li>Equipment operation must conform with national and local safety regulations.</li> </ul> <p><b>Failure to follow these instructions can result in death, serious injury, or equipment damage.</b></p> </div>	<p>nO</p>
<p>b F r</p>	<p><b>Motor frequency</b> (Same as bFr 1st level adjustment parameter) Set to 50 Hz or 60 Hz, depending on the motor nameplate rating.</p>	<p>60</p>
<p>I P L</p>	<p><b>Line phase loss fault configuration</b> This parameter is only accessible on 3-phase drive controllers.</p> <ul style="list-style-type: none"> <li>- n 0: inhibits the line phase loss fault</li> <li>- Y E 5: activates monitoring for a line phase loss</li> </ul>	<p>YES</p>

ENGLISH

Code	Description	Factory setting
5 C 5	<p><b>Configuration backup</b></p> <ul style="list-style-type: none"> <li>- n O : function inactive</li> <li>- 5 E 5 : saves the current configuration in EEPROM memory as a backup configuration. SCS automatically switches to nO as soon as the save is complete. Drive controllers ship with the current configuration and the backup configuration both set to the factory configuration.</li> </ul>	nO
F C 5	<p><b>Reset the configuration</b></p> <ul style="list-style-type: none"> <li>- n O : function inactive</li> <li>- r E C : resets the configuration to the backup configuration previously saved using SCS. rEC is only visible if a backup has been performed. FCS automatically switches to nO as soon as the reset is complete.</li> <li>- I n I : resets the configuration to the factory setting. FCS automatically switches to nO as soon as the reset is complete.</li> </ul> <p><i>NOTE: To perform the rEC and InI commands, you must hold down the ENT key for 2 s.</i></p>	nO

## MONITORING MENU SUP

The value of one of the monitoring parameters is displayed on the drive controller while it is running. Motor reference (parameter FrH) is the default display value.

To change the displayed monitoring parameter:

1. Use the up and down arrow keys to select the desired parameter.
2. Press the **ENT** key to display the parameter's value.
3. Press the **ENT** key again to store the change of the monitoring parameter.

The value of this parameter will be displayed during subsequent operation, even after drive controller power has been cycled. If the new choice is not stored by pressing the **ENT** key for a second time, the drive controller will return to the previous parameter after power has been cycled.

The following parameters are accessible for display with the drive controller stopped or running.

Code	Parameter	Unit
F r H	Reference frequency (factory configuration)	Hz
r F r	Output frequency applied to the motor	Hz
L C r	Motor current	A
U L n	Line voltage	V
t H r	Motor thermal state: 100% corresponds to the nominal thermal state. Above 118%, the drive controller trips on an OLF fault (motor overload). It can be reset when the thermal state drops below 100%.	%
t H d	Drive controller thermal state: 100% corresponds to the nominal thermal state. Above 118%, the drive controller trips on an OHF fault (drive controller overheating). It can be reset when the thermal state drops below 80%.	%

## DRIVE CONTROLLER DOES NOT START, NO FAULT DISPLAYED

The assignment of the fast stop or freewheel stop functions prevents the controller from starting if the corresponding logic inputs are not powered up. The ATV11 controller then displays nSt in freewheel stop mode and FSt in fast stop mode. This is normal since these functions are active at zero so that the controller will be stopped safely if there is a wire break.

On power-up or a manual fault reset or after a stop command, the motor can only be powered after the forward, reverse, and DC injection stop commands have been reset. If they have not been reset, the drive controller displays “rdY” but does not start. If the automatic restart function is configured (parameter Atr in the drC menu) and the drive controller is in 2-wire control, these commands are taken into account without a reset being necessary.

## FAULTS DISPLAYED

Faults cannot be reset until the cause is removed. Faults OHF, OLF, OSF, ObF, and PHF can be reset via a logic input (rSF) if configured for this function. Faults OHF, OLF, OSF, ObF, and PHF can be reset via automatic restart (ATR) if configured for this function and if the drive controller is configured for 2-wire control. Fault USF resets as soon as the fault is removed; neither a logic input nor automatic restart is required for the reset. All faults can be reset by cycling the power.

Fault	Probable cause	Corrective Action
- CFF configuration fault		- Restore the factory settings or the backup configuration, if it is valid. See parameter FCS in the FUn menu (see page 12).
- CrF precharge circuit	- precharge circuit damaged	- Reset the drive controller. - Replace the drive controller.
- InF internal fault	- internal fault - internal connection fault	- Remove sources of electromagnetic interference. - Replace the drive controller.
- ObF overvoltage during deceleration	- braking too rapidly or overhauling load	- Increase the deceleration time. - Install a braking resistor if necessary. - Activate the brA function if it is compatible with the application.
- OCF overcurrent	- acceleration too rapid - drive controller and/or motor undersized for load - mechanical blockage	- Adjust drive controller programming. - Ensure that the size of the motor and drive controller is sufficient for the load. - Clear mechanical blockage.
- OHF drive controller overload	- continuous motor current load too high or - ambient temperature too high	- Check the motor load, the drive controller ventilation, and the environment. Wait for the controller to cool before restarting. - Increase ACC for high inertia loads.
- OLF motor overload	- thermal trip due to prolonged motor overload - motor power rating too low for the application	- Check the setting of the motor thermal protection (ItH). See page 10. Check the motor load. Wait for the motor to cool before restarting.
- OSF overvoltage during steady state operation or during acceleration	- line voltage too high - induced voltage on output wiring	- Check the line voltage. Compare with the drive controller nameplate ratings. - Reset the drive controller. - Verify that the wiring is correct (see pages 5–8).

Fault	Probable cause	Corrective Action
- P H F input phase failure	- input phase loss, blown fuse - input phase imbalance - transient phase fault - 3-phase controller used on a single phase line supply - unbalanced load	- Verify that the input power is correct. - Check the line fuses. - Verify input power connections. - Supply 3-phase power if needed.  - Disable IPL (set to nO).
- S C F motor short-circuit	- short-circuit or grounding at the drive controller output	- Check the cables connecting the drive controller to the motor, and check the insulation of the motor.
- S O F overspeed	- instability - overhauling load	- Check the motor, gain, and stability parameters. - Add a braking module and resistor and verify the drive controller, motor, and load.
- U S F undervoltage	- input voltage too low - transient voltage dip - damaged precharge resistor	- Check that the line voltage matches the nameplate rating. - Check the setting of parameter UnS. - Replace the drive controller.

Square D Company  
 8001 Hwy 64 East  
 Knightdale, NC 27545  
 1-888-SquareD (1-888-778-2733)  
 www.SquareD.com

Electrical equipment should be installed, operated, serviced, and maintained only by qualified personnel. No responsibility is assumed by Schneider Electric for any consequences arising out of the use of this material.